

AIRSTAGE

AIR CONDITIONER

Wall-mounted type

FUJITSU

REFRIGERANT **R32**
INVERTER

DESIGN & TECHNICAL MANUAL

INDOOR



ASEH18KMTGL
ASEH24KMTGL

OUTDOOR



AOEH18KMTG



AOEH24KMTG

GENERAL Inc.

DR_AS265ES_01
2026.01.13

Notices:

- Product specifications and design are subject to change without notice for future improvement.
- For further details, please check with our authorized dealer.

Trademarks

“AIRSTAGE Mobile” is a trademark of GENERAL Inc.

Android and Google Play are trademarks of Google LLC.

App Store is a service mark of Apple Inc., registered in the U.S. and other countries.

IOS is a trademark or registered trademark of Cisco in the U.S. and other countries and is used under license.

CONTENTS

Part 1. INDOOR UNIT	1
1. Specifications	2
2. Wireless LAN control	4
2-1. System requirement.....	4
3. Dimensions	5
3-1. Models: ASEH18KMTGL and ASEH24KMTGL	5
3-2. Pipe exit length from the rear	7
4. Wiring diagrams	8
4-1. Models: ASEH18KMTGL and ASEH24KMTGL	8
5. Capacity table	9
5-1. Cooling capacity.....	9
5-2. Heating capacity	10
6. Fan performance	11
6-1. Air velocity distributions.....	11
6-2. Airflow	13
7. Operation noise (sound pressure)	15
7-1. Noise level curve.....	15
7-2. Sound level check point	16
8. Safety devices	17
9. External input and output	18
9-1. External input.....	19
9-2. External output.....	22
9-3. Setting of external input and output	24
9-4. Details of control input function	25
9-5. Details of control output function.....	29
10. Group connection	31
11. Remote controller	32
11-1. Wireless remote controller	32
12. Function settings	34
12-1. Function settings by using remote controller	34
12-2. Custom code setting for wireless remote controller.....	40
13. Accessories	41
13-1. Models: ASEH18KMTGL and ASEH24KMTGL	41
14. Optional parts	42
14-1. Controllers	42
14-2. Others	44

CONTENTS (continued)

Part 2. OUTDOOR UNIT	45
1. Specifications	46
2. Dimensions	47
2-1. Model: AOEH18KMTG.....	47
2-2. Model: AOEH24KMTG.....	48
3. Installation space	49
3-1. Models: AOEH18KMTG and AOEH24KMTG.....	49
4. Refrigerant circuit	52
4-1. Model: AOEH18KMTG.....	52
4-2. Model: AOEH24KMTG.....	53
5. Wiring diagrams	54
5-1. Model: AOEH18KMTG.....	54
5-2. Model: AOEH24KMTG.....	55
6. Capacity compensation rate for pipe length and height difference	56
6-1. Model: AOEH18KMTG.....	56
6-2. Model: AOEH24KMTG.....	57
7. Additional charge calculation	58
7-1. Model: AOEH18KMTG.....	58
7-2. Model: AOEH24KMTG.....	58
8. Airflow	59
8-1. Model: AOEH18KMTG.....	59
8-2. Model: AOEH24KMTG.....	59
9. Operation noise (sound pressure)	60
9-1. Noise level curve.....	60
9-2. Sound level check point.....	61
10. Electrical characteristics	62
11. Safety devices	63
12. Accessories	64
12-1. Models: AOEH18KMTG and AOEH24KMTG.....	64

Part 1. INDOOR UNIT

WALL-MOUNTED TYPE:

ASEH18KMTGL

ASEH24KMTGL

1. Specifications

Type				Wall mounted		
				Inverter, Heat pump		
Model name				ASEH18KMTGL	ASEH24KMTGL	
Power supply intake				Outdoor unit		
System power supply	Voltage		V	230		
	Frequency		Hz	50		
	Available voltage range		V	198—264		
Indoor unit power supply (from outdoor unit)				V	230	
Capacity	Cooling	Rated	kW	5.2	7.1	
			Btu/h	17,700	24,200	
		Min.—Max.	kW	0.9—6.0	0.9—8.3	
	Heating	Rated	kW	6.3	8.0	
			Btu/h	21,500	27,200	
		Min.—Max.	kW	0.9—8.7	0.9—10.1	
				Btu/h	3,100—29,600	
Input power	Cooling	Rated	kW	1.39	2.20	
		Min.—Max.		0.09—1.66	0.24—3.15	
	Heating	Rated	1.56	1.99		
		Min.—Max.	0.09—2.86	0.14—3.00		
	Fan	HIGH	W	37.5	61.6	
		MED		22.9	26.7	
		LOW		13.3		
		QUIET		8.2		
Current	Cooling	Rated	A	6.1	9.8	
	Heating			7.0	8.8	
Energy efficiency class	Cooling		A ⁺⁺			
	Heating (Average)		A ⁺			
Pdesign	Cooling		kW	5.2	7.1	
	Heating (Average)			4.8	7.1	
SEER	Cooling		kWh/kWh	8.0	7.3	
SCOP	Heating (Average)			4.6	4.3	
Annual energy consumption	QCE		kWh/a	227	340	
	QHE (Average)			1,460	2,311	
EER	Cooling		kW/kW	3.74	3.23	
COP	Heating			4.04	4.02	
Sensible capacity	Cooling		kW	4.05	5.30	
Power factor	Cooling		%	99	98	
	Heating			97	98	
Moisture removal			L/h (pints/h)	1.7 (3.0)	2.7 (4.8)	
Maximum operating current*1	Cooling		A	9.5	13.5	
	Heating			13.5	16.0	
Fan	Airflow rate	Cooling	m ³ /h	HIGH	980	1,170
				MED	810	850
				LOW	640	
				QUIET	510	
		Heating		HIGH	1,020	1,170
				MED	850	
				LOW	640	
				QUIET	510	
	Type × Qty	Crossflow fan × 1				
	Motor output			W	59	
Sound pressure level*2	Cooling		dB (A)	HIGH	45	49
				MED	40	
				LOW	35	
				QUIET	29	
	Heating			HIGH	46	49
				MED	40	
				LOW	35	
				QUIET	29	
Sound power level	Cooling	HIGH	dB (A)	60	65	
	Heating			61	65	
Heat exchanger	Dimensions (H × W × D)		mm	Main 1: 210 × 798 × 26.6 Main 2: 135 × 798 × 20.0 Sub 1: 84 × 798 × 13.3 Sub 2: 84 × 798 × 13.3		
	Fin pitch			Main 1: 1.2 Main 2: 1.1 Sub 1: 1.4 Sub 2: 1.4		
	Rows × Stages		Main 1: 2 × 10 Main 2: 2 × 8 Sub 1: 1 × 4 Sub 2: 1 × 4			
	Pipe type		Copper tube			
	Fin type		Aluminum			
	Material		Polystyrene			
Enclosure	Color		White Approximate color of Munsell 9PB 9.1/0.2			
	Net		mm	280 × 980 × 240		
Gross		322 × 1,078 × 346				
Weight	Net		kg	12.5		
	Gross			18.5		
Connection pipe	Size	Liquid	mm (in)	Ø6.35 (Ø1/4)		
		Gas		Ø12.70 (Ø1/2)		
	Method		Flare			
Drain hose	Material		Polypropylene + High-density polyethylene			
	Tip diameter		mm Ø13.8 (I.D.), Ø15.8 to Ø16.7 (O.D.)			

Type			Wall mounted	
			Inverter, Heat pump	
Model name			ASEH18KMTGL	ASEH24KMTGL
Operation range	Cooling	°C	18 to 32	
		%RH	80 or less	
	Heating	°C	16 to 30	
Remote controller type			Wireless (Option: Wired, Mobile app* ³ [AIRSTAGE Mobile])	
<p>NOTES:</p> <ul style="list-style-type: none"> Specifications are based on the following conditions: <ul style="list-style-type: none"> Cooling: Indoor temperature of 27°CDB/19°CWB, and outdoor temperature of 35°CDB/24°CWB. Heating: Indoor temperature of 20°CDB/15°CWB, and outdoor temperature of 7°CDB/6°CWB. Pipe length: 5.0 m, Height difference: 0 m. (Between outdoor unit and indoor unit.) Protective function might work when using it outside the operation range. *1: Maximum operating current is the total current of the indoor unit and the outdoor unit. *2: Sound pressure level: <ul style="list-style-type: none"> Measured values in manufacturer's anechoic chamber. Because of the surrounding sound environment, the sound levels measured in actual installation conditions might be higher than the specified values here. *3: Available on Google Play™ store or on App Store®. This data is based on EN 14511 standard. 				

2. Wireless LAN control

By installing mobile app on a smart device, several functions can be controlled from outside the house.

2-1. System requirement

Before using this function, prepare the following items:

- **Wireless router:**

Wireless LAN standard	IEEE802.11b/g/n
Frequency bands*	<ul style="list-style-type: none"> • U.S.A., Canada: 2.4 GHz (1ch—11ch) • Other countries: 2.4 GHz (1ch—13ch)
Network security standard	<ul style="list-style-type: none"> • Open • WEP • WPA (PSK) • WPA2 Personal (PSK) • WPS for same-LAN registration

*: Usable only in the country or region where you purchased the product.

To check whether your wireless router complies with the network security standards listed above, refer to the operation manual.

- **Smartphone:**

App-compliant operating system	iOS	Check the latest version of supported OS at Google Play store or App Store.
	Android™	

- **AIRSTAGE Mobile (mobile application):**

Mobile app is available on Google Play store or on App Store.

After installation of mobile app, user registration is required. For user registration and setup information, refer to Setting Manual attached with the product.

For the latest version of the wireless LAN control manuals, refer to the following web site.

<https://www.generalww.com/global/support/>

3. Dimensions

3-1. Models: ASEH18KMTGL and ASEH24KMTGL

Unit: mm

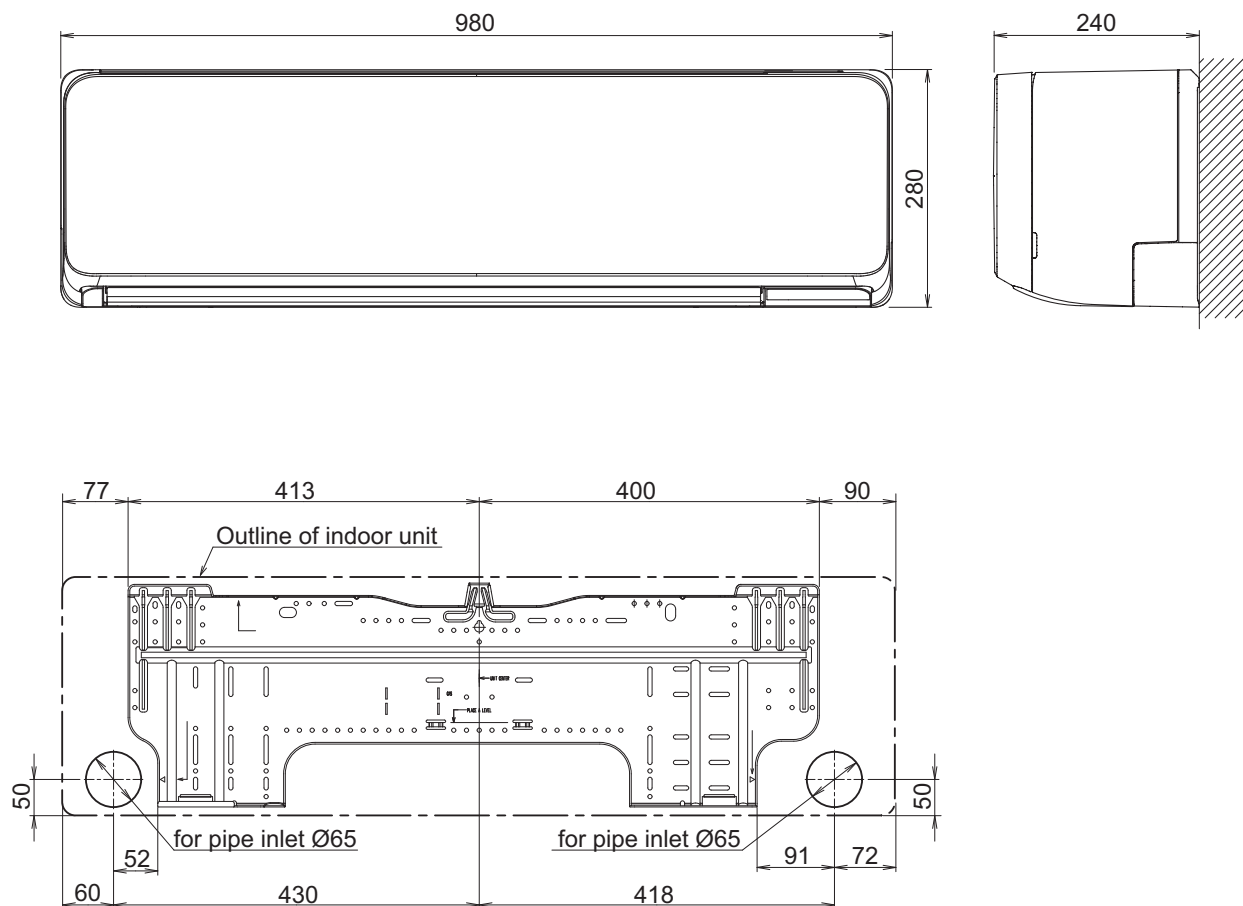

■ Installation space requirement

Provide sufficient installation space for product safety.

Unit: mm

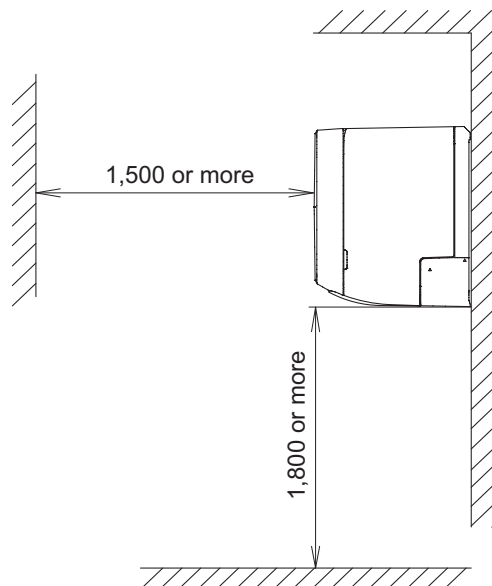
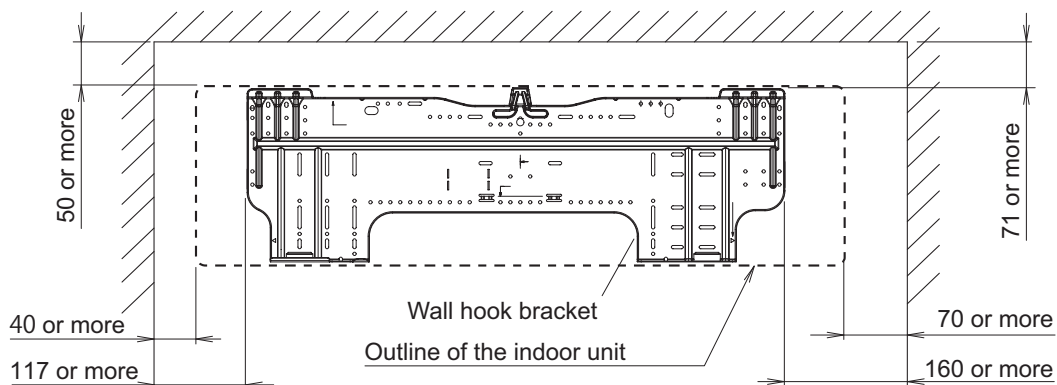

3-2. Pipe exit length from the rear

Design the system considering the length of the pipes or hose exiting from the rear of the indoor unit.

NOTE: Detailed shapes of the indoor unit and the tip of each pipe or hose may vary depending on the model.

Unit: mm

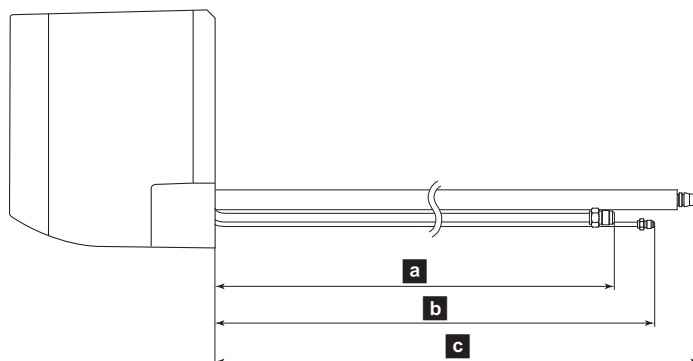

Model name	Approximate length		
	a Gas pipe	b Liquid pipe	c Drain hose
ASEH18-24KMTGL	430	485	470

4. Wiring diagrams

4-1. Models: ASEH18KMTGL and ASEH24KMTGL

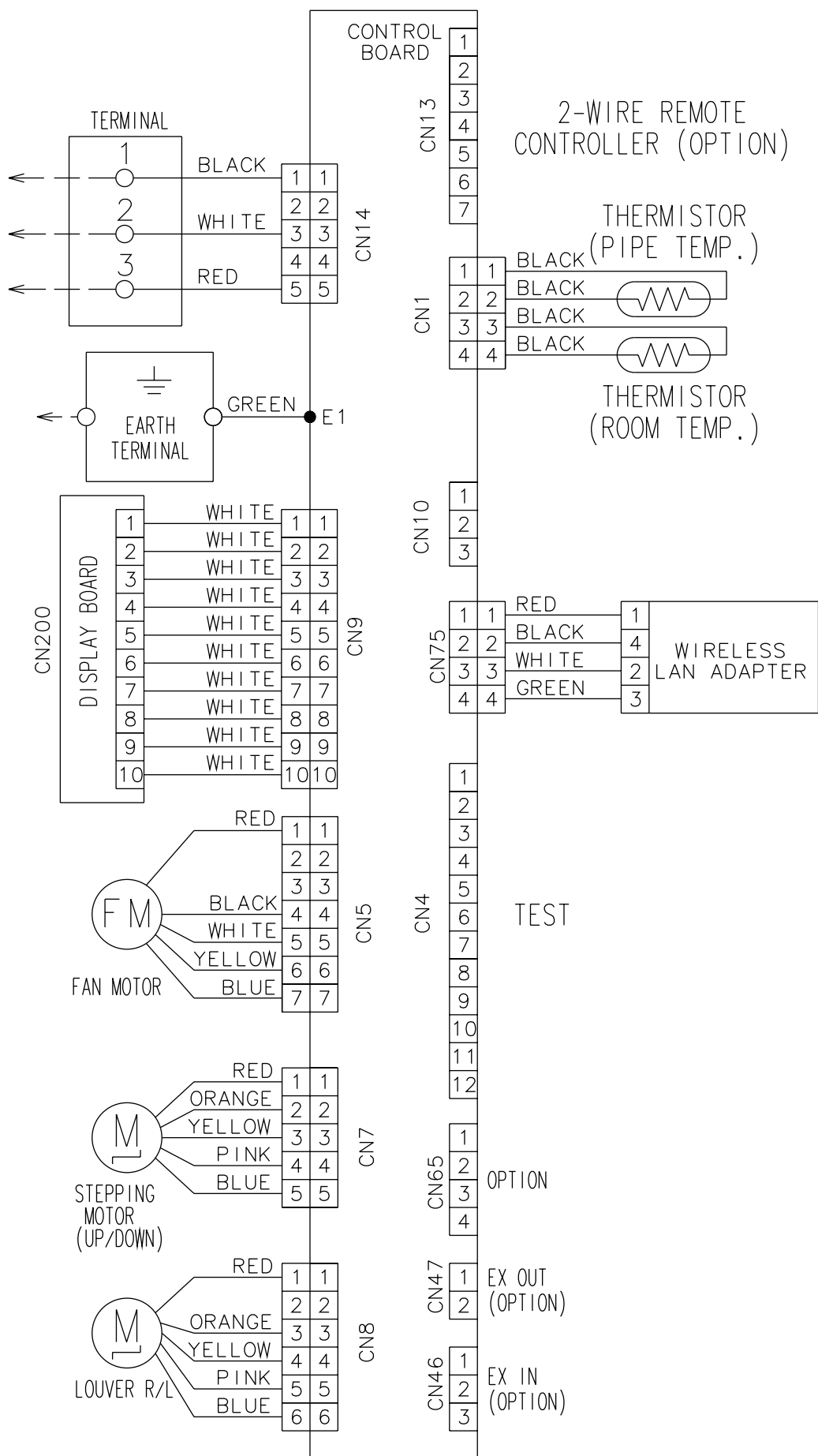

5. Capacity table

Capacity tables show each of following values calculated based on the outdoor temperature and the indoor temperature, under given Airflow Rate (AFR):

For cooling capacity: Total Capacity (TC), Sensible Heat Capacity (SHC), and Input Power (IP)

For heating capacity: Total Capacity (TC) and Input Power (IP)

5-1. Cooling capacity

■ Model: ASEH18KMTGL

AFR			m ³ /h									980									
Outdoor temperature	Indoor temperature																				
	18			21			23			25			27			29			32		
	12			15			16			18			19			21			23		
	°CDB	TC	SHC	IP	TC	SHC	IP	TC	SHC	IP	TC	SHC	IP	TC	SHC	IP	TC	SHC	IP	TC	SHC
-10	3.18	2.84	0.46	3.48	3.11	0.46	3.59	3.21	0.46	3.82	3.41	0.47	3.93	3.52	0.47	4.19	3.75	0.48	4.47	3.99	0.48
-5	2.98	2.76	0.55	3.26	3.02	0.55	3.36	3.11	0.56	3.58	3.31	0.56	3.69	3.41	0.57	3.93	3.63	0.58	4.19	3.87	0.58
0	2.78	2.68	0.64	3.05	2.93	0.65	3.14	3.02	0.65	3.34	3.21	0.66	3.44	3.31	0.67	3.67	3.52	0.67	3.91	3.76	0.68
5	3.12	2.81	0.44	3.41	3.07	0.44	3.52	3.17	0.45	3.74	3.37	0.45	3.86	3.47	0.45	4.11	3.70	0.46	4.38	3.94	0.46
10	2.95	2.74	0.52	3.23	3.00	0.53	3.33	3.09	0.53	3.54	3.29	0.54	3.65	3.39	0.54	3.88	3.61	0.55	4.14	3.85	0.55
15	3.83	3.11	0.57	4.19	4.30	0.57	4.32	3.51	0.58	4.60	3.73	0.58	4.74	3.84	0.59	5.05	4.09	0.60	5.38	4.37	0.60
20	4.61	3.45	0.93	5.05	3.77	0.94	5.20	3.89	0.95	5.53	4.13	0.96	5.70	4.26	0.97	6.07	4.54	0.98	6.48	4.48	0.99
25	4.49	3.40	1.05	4.92	3.72	1.06	5.07	3.83	1.07	5.39	4.08	1.08	5.56	4.20	1.09	5.92	4.48	1.10	6.31	4.77	1.11
30	4.35	3.34	1.19	4.76	3.65	1.20	4.91	3.76	1.21	5.22	4.00	1.23	5.38	4.13	1.24	5.73	4.40	1.25	6.11	4.69	1.26
35	4.21	3.28	1.33	4.60	3.59	1.35	4.74	3.69	1.36	5.04	3.93	1.38	5.20	4.05	1.39	5.54	4.32	1.40	5.91	4.60	1.42
40	3.92	3.14	1.42	4.29	3.34	1.44	4.42	3.44	1.45	4.70	3.77	1.47	4.85	3.88	1.48	5.17	4.14	1.50	5.51	4.41	1.51
45	3.45	2.91	1.47	3.78	3.18	1.48	3.90	3.28	1.50	4.14	3.48	1.51	4.27	3.59	1.53	4.55	3.83	1.55	4.85	4.08	1.56
50	3.10	2.74	1.55	3.40	2.96	1.55	3.51	3.43	1.58	3.73	3.28	1.58	3.84	3.38	1.61	4.10	3.61	1.63	4.36	3.84	1.64

■ Model: ASEH24KMTGL

AFR			m ³ /h									1,170									
Outdoor temperature	Indoor temperature																				
	18			21			23			25			27			29			32		
	12			15			16			18			19			21			23		
	°CDB	TC	SHC	IP	TC	SHC	IP	TC	SHC	IP	TC	SHC	IP	TC	SHC	IP	TC	SHC	IP	TC	SHC
-10	4.34	3.72	0.68	4.75	4.07	0.69	4.90	4.20	0.70	5.21	4.46	0.70	5.37	4.60	0.71	5.72	4.90	0.72	6.10	5.23	0.72
-5	4.07	3.61	0.82	4.46	3.95	0.83	4.59	4.07	0.84	4.88	4.33	0.84	5.03	4.46	0.85	5.36	4.76	0.86	5.72	5.07	0.87
0	3.80	3.50	0.96	4.16	3.83	0.97	4.28	3.95	0.98	4.56	4.20	0.99	4.70	4.33	1.00	5.01	4.61	1.01	5.34	4.92	1.02
5	4.26	3.68	0.65	4.66	4.02	0.66	4.80	4.14	0.67	5.11	4.41	0.67	5.27	4.54	0.68	5.61	4.84	0.69	5.98	5.16	0.69
10	4.03	3.59	0.78	4.41	3.92	0.79	4.54	4.04	0.80	4.83	4.30	0.81	4.98	4.43	0.81	5.30	4.72	0.82	5.65	5.04	0.83
15	5.23	4.07	0.85	5.73	4.45	0.85	5.90	4.59	0.86	6.27	4.88	0.87	6.47	5.03	0.88	6.89	5.36	0.89	7.35	5.71	0.90
20	6.29	4.51	1.39	6.89	4.94	1.41	7.10	5.09	1.42	7.55	5.41	1.44	7.78	5.58	1.45	8.29	5.95	1.46	8.84	6.34	1.48
25	6.14	4.45	1.56	6.71	4.87	1.58	6.92	5.02	1.60	7.36	5.34	1.61	7.59	5.50	1.63	8.08	5.85	1.65	8.62	6.25	1.66
30	5.94	4.37	1.78	6.50	4.78	1.80	6.70	4.93	1.82	7.12	5.24	1.84	7.34	5.40	1.86	7.82	5.75	1.87	8.34	6.13	1.89
35	5.74	4.29	2.11	6.28	4.69	2.14	6.48	4.83	2.15	6.89	5.14	2.18	7.10	5.30	2.20	7.57	5.65	2.22	8.07	6.02	2.25
40	5.36	4.11	2.13	5.86	4.50	2.15	6.04	4.63	2.18	6.42	4.93	2.20	6.62	5.08	2.22	7.05	5.24	2.24	7.52	5.77	2.26
45	4.72	3.80	2.20	5.16	4.16	2.22	5.32	4.29	2.24	5.66	4.56	2.27	5.83	4.70	2.29	6.21	5.01	2.31	6.62	5.34	2.34
50	4.25	3.58	2.24	4.65	3.92	2.25	4.79	4.04	2.28	5.09	4.30	2.30	5.25	4.43	2.33	5.58	4.66	2.35	5.95	5.03	2.38

5-2. Heating capacity

NOTE: Values mentioned in the table are calculated based on the maximum capacity.

■ Model: ASEH18KMTGL

AFR	m ³ /h	1,020
-----	-------------------	-------

			Indoor temperature													
			16		18		20		22		24		26		28	
Outdoor temperature	°CDB	°CWB	TC	IP	TC	IP	TC	IP	TC	IP	TC	IP	TC	IP	TC	IP
			kW		kW		kW		kW		kW		kW		kW	
		-15	-16	5.17	1.92	5.04	1.96	4.90	2.00	4.76	2.04	4.63	2.08	4.49	2.12	4.36
	-10	-11	6.23	1.89	6.06	1.93	5.90	1.98	5.74	2.01	5.57	2.04	5.41	2.09	5.25	2.13
	-5	-7	7.31	2.11	7.12	2.15	6.93	2.07	6.74	2.24	6.55	2.28	6.36	2.33	6.17	2.37
	0	-2	8.45	2.71	8.23	2.76	8.01	2.70	7.79	2.87	7.57	2.93	7.34	2.99	7.12	3.05
	5	3	9.36	3.18	9.11	3.25	8.87	3.32	8.63	3.38	8.38	3.44	8.14	3.52	7.89	3.58
	7	6	9.18	2.75	8.94	2.80	8.70	2.86	8.46	2.91	8.22	2.97	7.98	3.03	7.74	3.09
	10	8	9.29	2.64	9.05	2.69	8.81	2.79	8.56	2.81	8.32	3.86	8.08	2.92	7.83	2.97
	15	10	9.35	2.28	9.11	2.32	8.86	2.46	8.62	2.42	8.37	2.46	8.13	2.52	7.88	2.56
	20	15	9.42	2.04	9.17	2.09	8.93	2.17	8.68	2.17	8.43	2.21	8.19	2.26	7.94	2.30
	24	18	9.48	1.89	9.23	1.93	8.98	1.97	8.73	2.01	8.48	2.05	8.24	2.09	7.99	2.13

■ Model: ASEH24KMTGL

AFR	m ³ /h	1,170
-----	-------------------	-------

			Indoor temperature													
			16		18		20		22		24		26		28	
Outdoor temperature	°CDB	°CWB	TC	IP	TC	IP	TC	IP	TC	IP	TC	IP	TC	IP	TC	IP
			kW		kW		kW		kW		kW		kW		kW	
		-15	-16	6.56	2.76	6.39	2.81	6.22	2.87	6.05	2.93	5.88	2.98	5.70	3.05	5.53
	-10	-11	7.41	2.83	7.21	2.89	7.02	2.94	6.82	3.01	6.63	3.07	6.44	3.13	6.24	3.19
	-5	-7	8.25	2.96	8.04	3.02	8.05	3.04	7.60	3.15	7.39	3.21	7.17	3.27	6.96	3.33
	0	-2	9.10	3.17	8.86	3.24	8.63	3.26	8.39	3.37	8.15	3.43	7.91	3.50	7.67	3.57
	5	3	9.78	3.34	9.53	3.41	9.73	3.48	9.01	3.55	8.76	3.61	8.50	3.69	8.25	3.76
	7	6	10.66	2.88	10.38	2.94	10.10	3.00	9.82	3.06	9.54	3.11	9.26	3.18	8.98	3.24
	10	8	10.78	2.77	10.50	2.83	10.22	2.93	9.94	2.94	9.66	3.00	9.37	3.06	9.08	3.12
	15	10	10.86	2.39	10.58	2.44	10.29	2.58	10.01	2.54	9.72	2.59	9.44	2.64	9.15	2.69
	20	15	10.93	2.15	10.65	2.19	10.36	2.28	10.07	2.28	9.79	2.32	9.50	2.37	9.22	2.41
	24	18	11.00	1.99	10.71	2.03	10.42	2.07	10.13	2.11	9.84	2.15	9.56	2.19	9.27	2.24

6. Fan performance

6-1. Air velocity distributions

Model: ASEH18KMTGL

Measuring conditions	Fan speed	Operation mode
	HIGH	FAN

Top view
Horizontal louver: Up
Vertical louver: Center

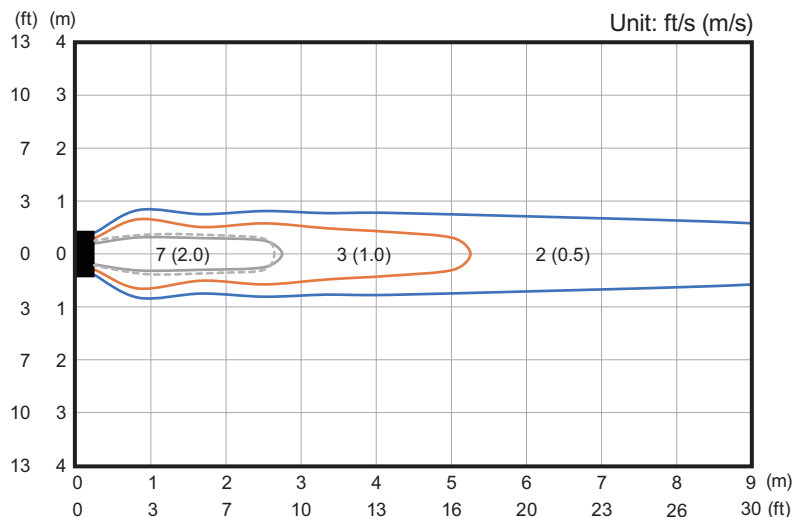

Top view
Horizontal louver: Up
Vertical louver: Left & Right

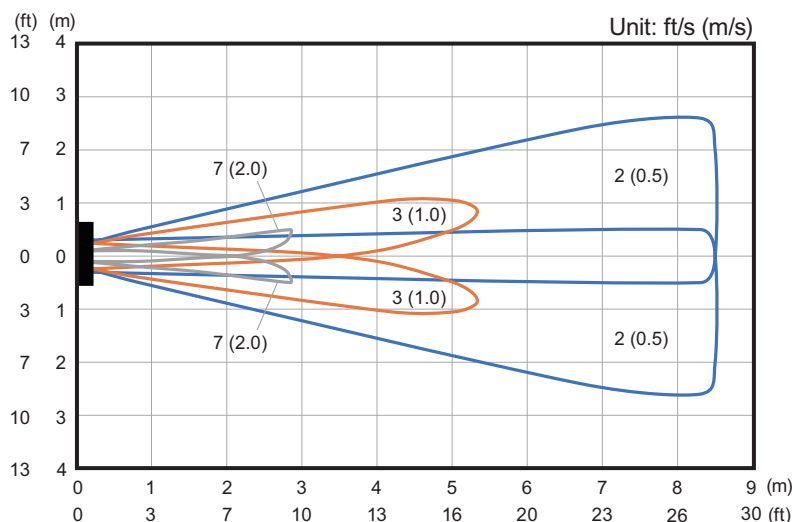

Side view
Horizontal louver: Up
Vertical louver: Center

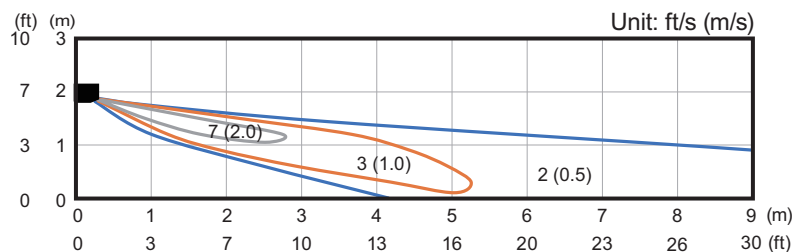

Side view
Horizontal louver: Down
Vertical louver: Center

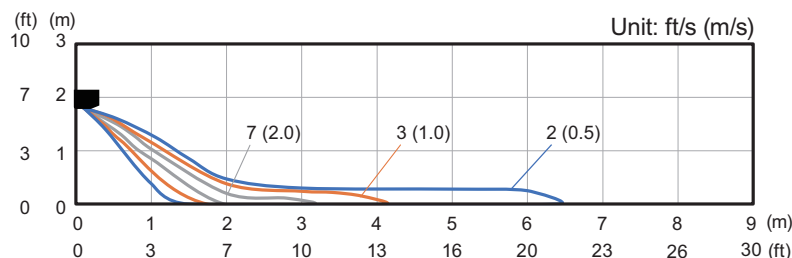

Model: ASEH24KMTGL

WALL MOUNTED
ASEH18-24KMTGL

WALL MOUNTED
ASEH18-24KMTGL

Measuring conditions	Fan speed	Operation mode
	HIGH	FAN

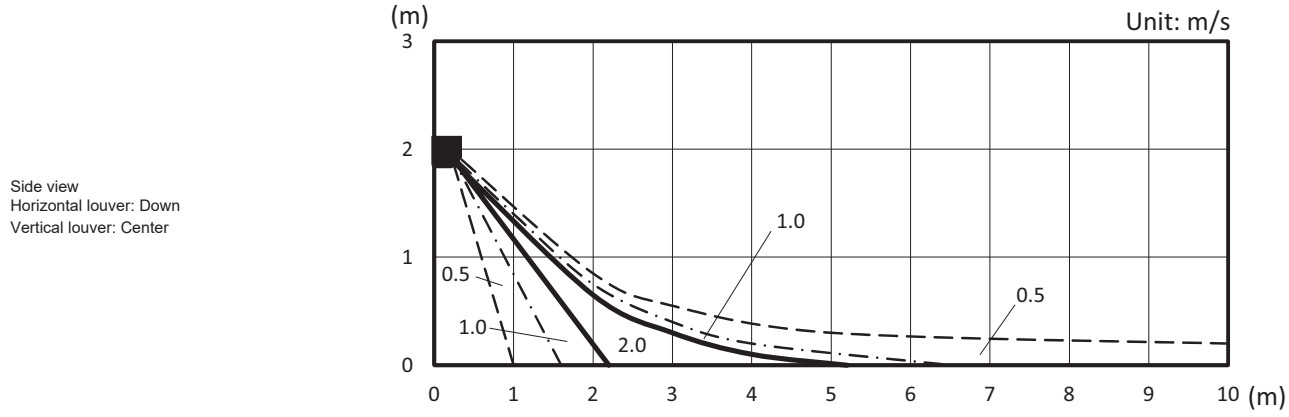
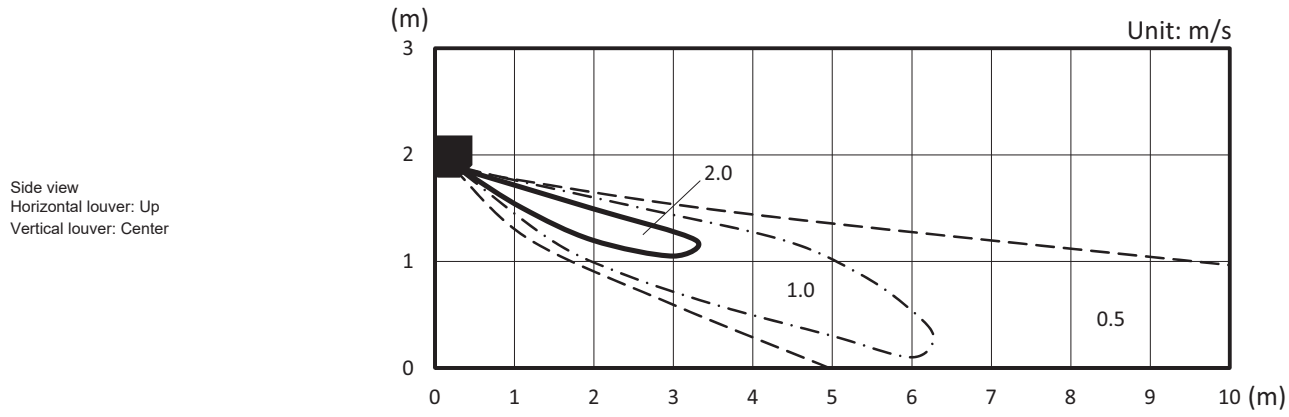
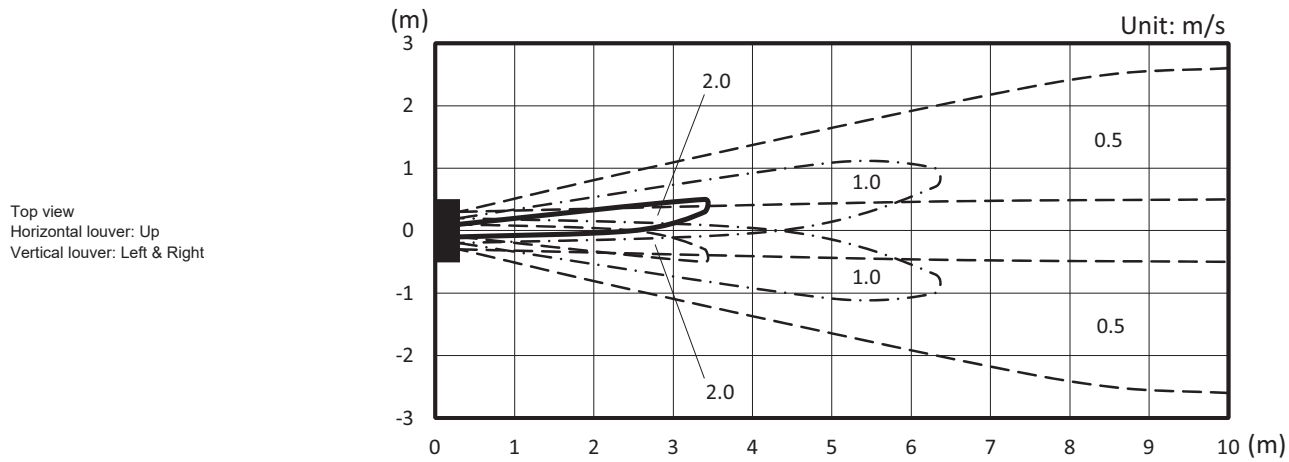
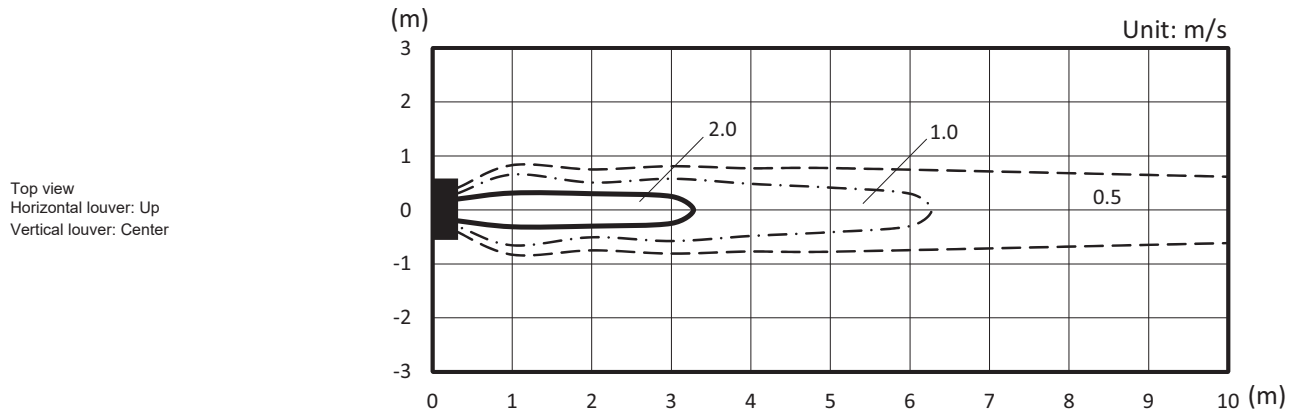

6-2. Airflow

■ Model: ASEH18KMTGL

● Cooling

Fan speed	Airflow	
HIGH	m ³ /h	980
	l/s	272
	CFM	577
MED	m ³ /h	810
	l/s	225
	CFM	477
LOW	m ³ /h	640
	l/s	178
	CFM	377
QUIET	m ³ /h	510
	l/s	142
	CFM	300

● Heating

Fan speed	Airflow	
HIGH	m ³ /h	1,020
	l/s	283
	CFM	600
MED	m ³ /h	850
	l/s	236
	CFM	500
LOW	m ³ /h	640
	l/s	178
	CFM	377
QUIET	m ³ /h	510
	l/s	142
	CFM	300

■ Model: ASEH24KMTGL

● Cooling

Fan speed	Airflow	
HIGH	m ³ /h	1,170
	l/s	325
	CFM	689
MED	m ³ /h	850
	l/s	236
	CFM	500
LOW	m ³ /h	640
	l/s	178
	CFM	377
QUIET	m ³ /h	510
	l/s	142
	CFM	300

● Heating

Fan speed	Airflow	
HIGH	m ³ /h	1,170
	l/s	325
	CFM	689
MED	m ³ /h	850
	l/s	236
	CFM	500
LOW	m ³ /h	640
	l/s	178
	CFM	377
QUIET	m ³ /h	510
	l/s	142
	CFM	300

7. Operation noise (sound pressure)

7-1. Noise level curve

Model: ASEH18KMTGL

Cooling

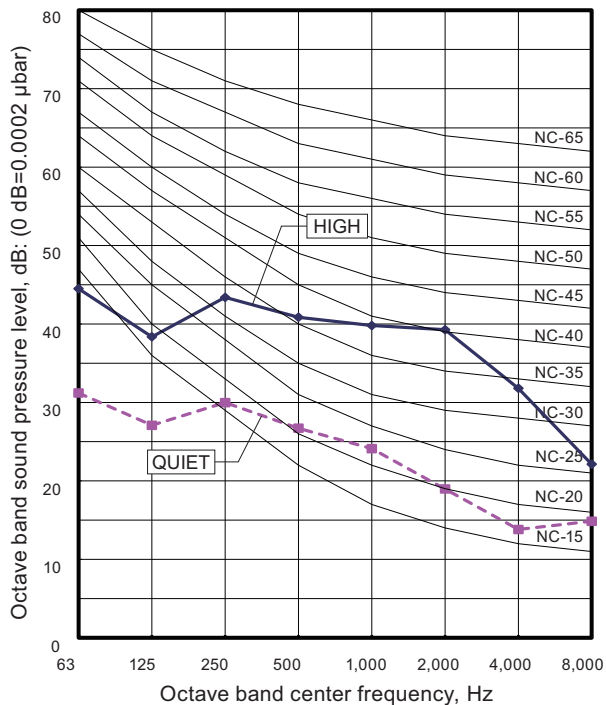

Heating

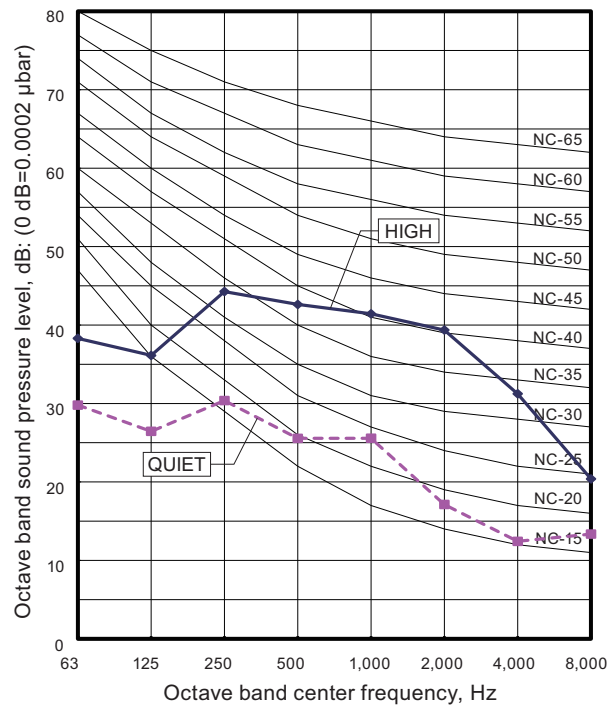

Model: ASEH24KMTGL

Cooling

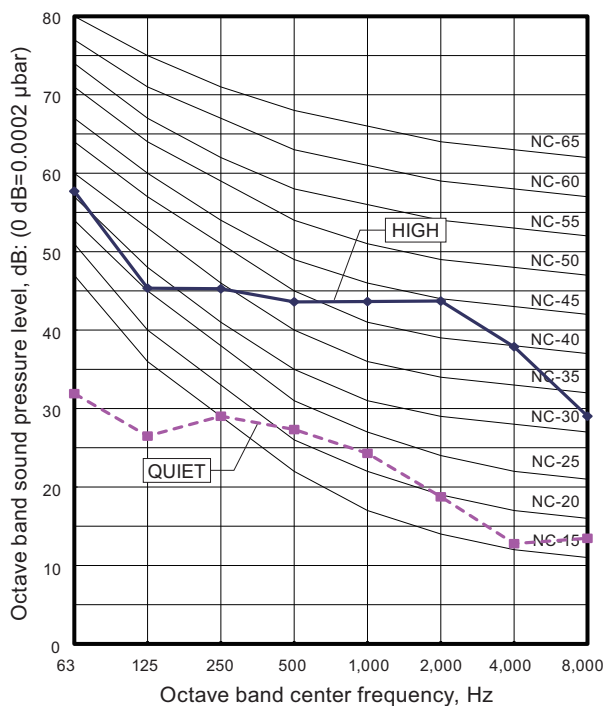

Heating

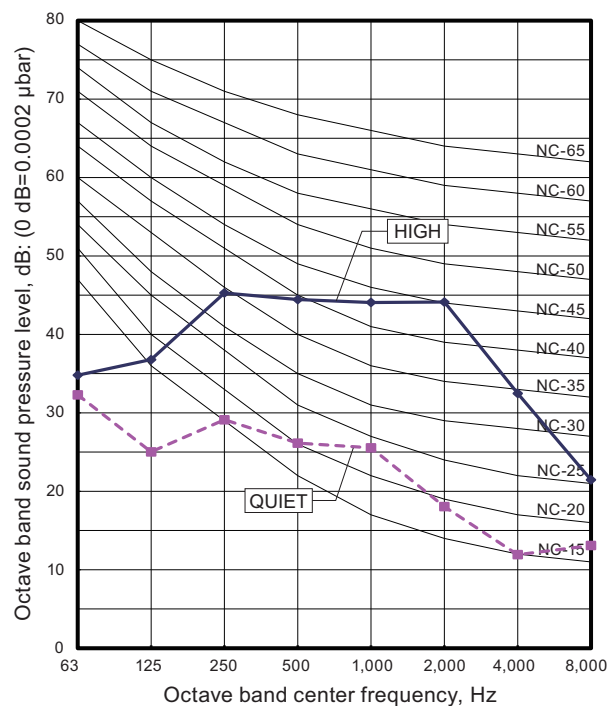

7-2. Sound level check point

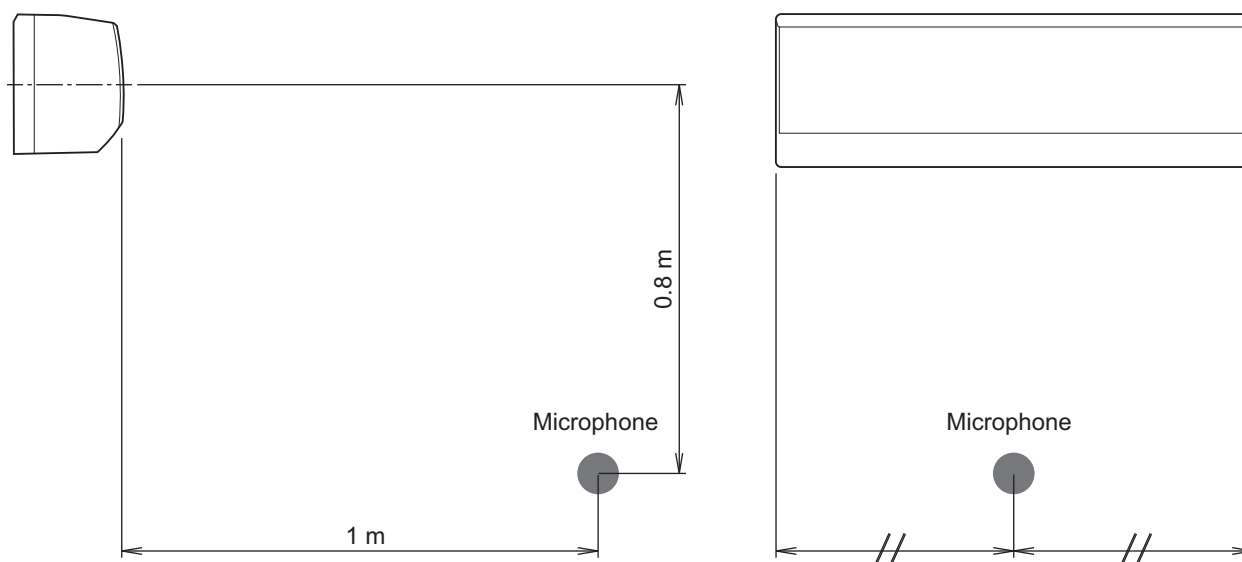

NOTE: Detailed shape of the actual indoor unit might be slightly different from the one illustrated above.

8. Safety devices

Type of protection	Protection form		Model
			ASEH18KMTGL ASEH24KMTGL
Circuit protection	Current fuse (PCB*)		250 V, 3.15 A
Fan motor protection	Thermal protector protection	Activate	125 ±10°C Fan motor stop
		Reset	100 ±10°C Fan motor restart

*PCB: Printed Circuit Board

9. External input and output

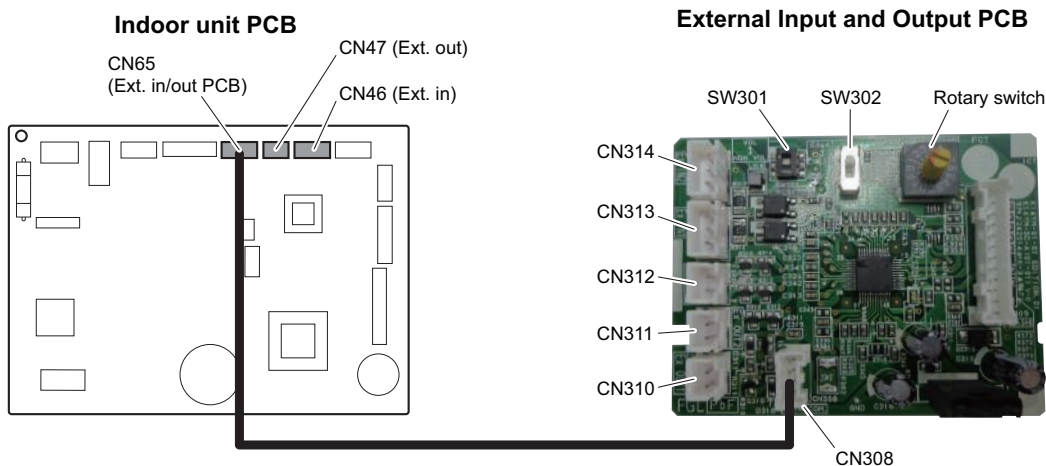

Connecting point		Input/Output	Function	Input select	Input signal
Indoor unit	CN46	Input	Operation/Stop	Dry contact	Edge
			Forced stop		
	CN47	Output	Operation/Stop	—	—
			Error status Indoor unit fan operation status		
External Input and Output PCB (UTY-XCSXZ2)	CN313 CN314	Input	Operation/Stop	Dry contact/Apply voltage	Edge/Pulse
			Forced stop		
			Forced thermostat off		Edge
	CN310 CN311 CN312	Output	Operation/Stop	—	—
			Error status		
			Indoor unit fan operation status		

NOTE: For details of the switching function, refer to "[Setting of external input and output](#)" on page 24.

9-1. External input

With using external input function, some functions on this product can be controlled from an external device.

- “Operation/Stop” mode or “Forced stop” mode can be selected with function setting of indoor unit.
- A twisted pair cable should be used. Maximum length of cable is 150 m.
- Use an external input and output cable with appropriate external dimension, depending on the number of cables to be installed.
- The wire connection should be separate from the power cable line.

■ Indoor unit

Indoor unit functions such as Operation/Stop can be done by using indoor unit connectors.

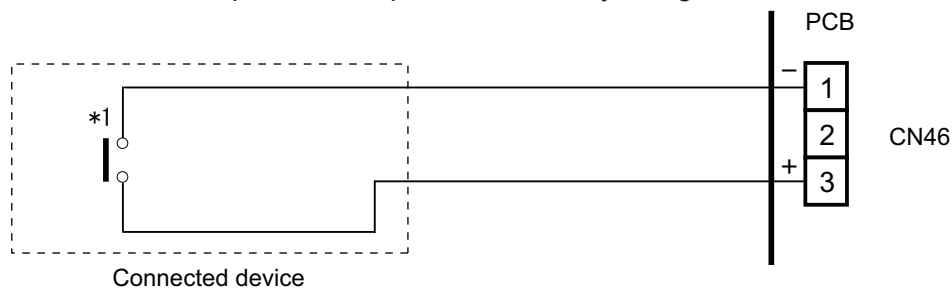

*1: The switch can be used on the following condition: DC 12 V to 24 V, 1 mA to 15 mA.

External Input and Output PCB

The indoor unit Operation/Stop can be set by using the input connector on the PCB.

Input select

Use either one of these types of connectors according to the application. (Both types of connectors cannot be used simultaneously.)

– Dry contact

In case of internal power supply, set the slide switch of SW301 to "NON VOL" side.

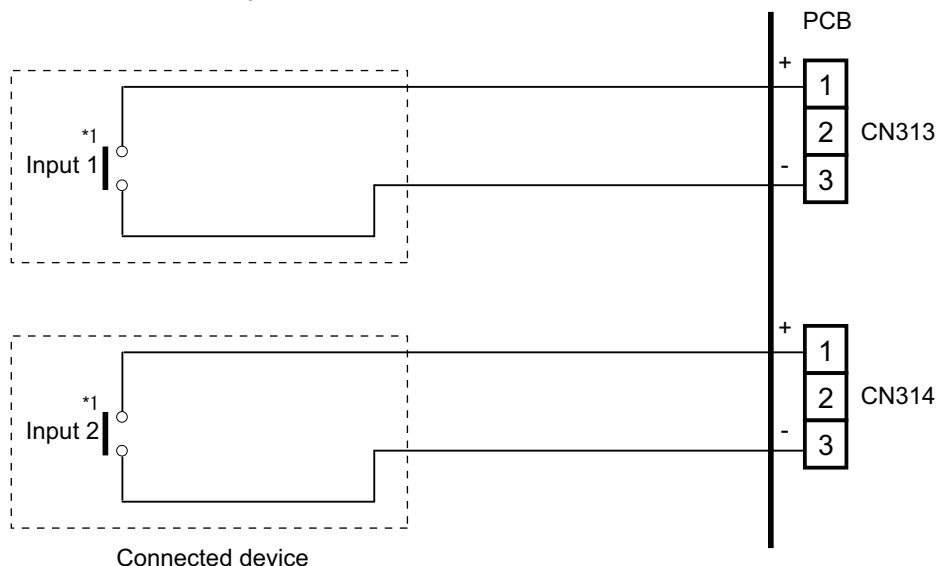

*1: The switches can be used on the following condition: DC 12 V to 24 V, 1 mA to 15 mA.

– Apply voltage

In case of external power supply, set the slide switch of SW301 to "VOL" side.

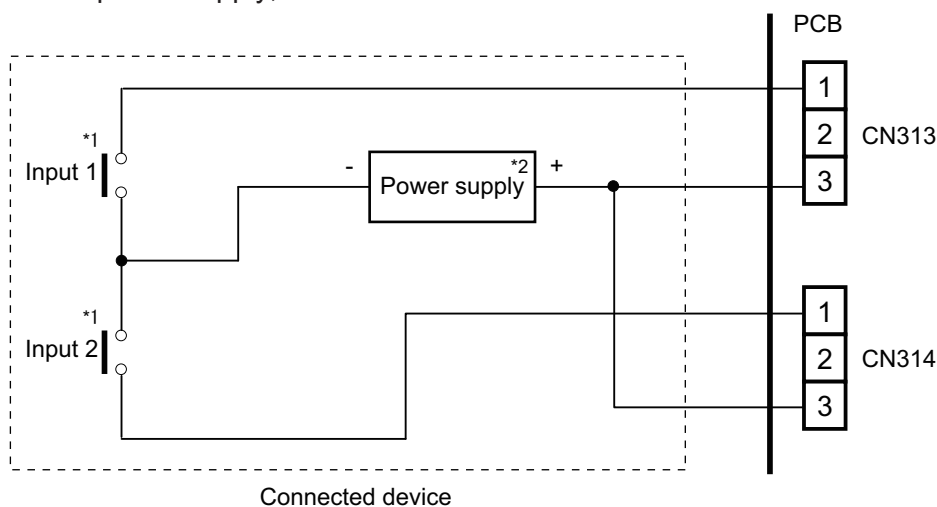

*1: The switches can be used on the following condition: DC 12 V to 24 V, 1 mA to 15 mA.

*2: Make the power supply DC 12 V to 24 V, 10 mA or more.

■ Input signal type

- **Indoor unit**

Input signal type is only "Edge".

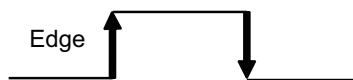

- **External Input and Output PCB**

The input signal type can be selected.

Signal type (edge or pulse) can be switched by the DIP switch 2 (SW302) on the External Input and Output PCB.

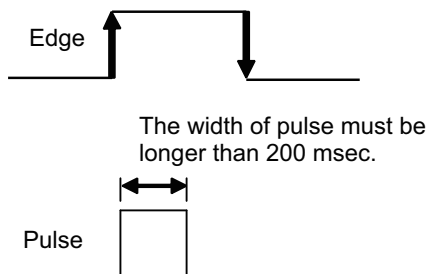

NOTE: The input signal supports the following switch type:

- Edge: Alternate type switch
- Pulse: Momentary type switch

9-2. External output

Use an external output cable with appropriate external dimension, depending on the number of cables to be installed.

Indoor unit

- A twisted pair cable should be used. Maximum length of cable is 25 m.
- Output voltage: High DC 12 V \pm 2 V, Low 0 V.
- Permissible current: 50 mA.
- For details, refer to "[Setting of external input and output](#)" on page 24.

- **When indicator, etc. are connected directly**

Example: Function setting number 60 is set to "00".

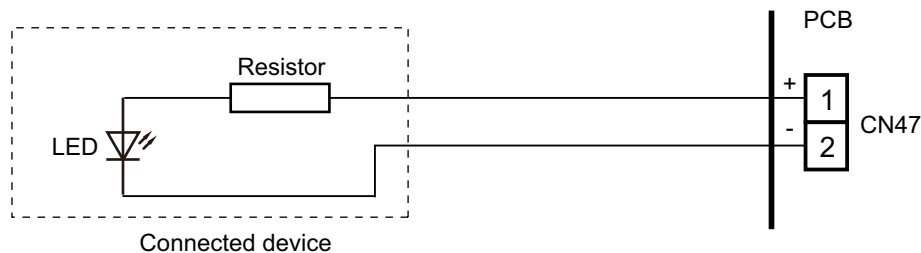

- **When connecting with a device equipped with a power supply**

Example: Function setting number 60 is set to "00".

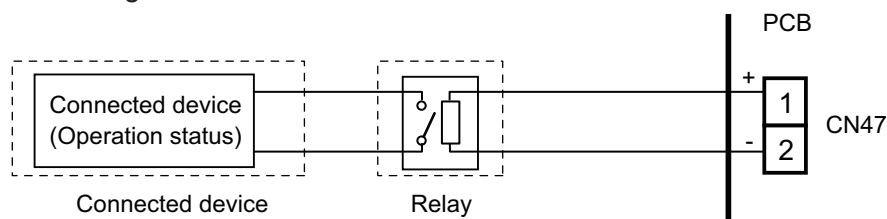

External Input and Output PCB

- A twisted pair cable should be used. Maximum length of cable is 25 m.
- Output voltage: High DC 12 V \pm 2 V, Low 0 V.
- Permissible current: 50 mA.
- For details, refer to "[Setting of external input and output](#)" on page 24.
- **When indicator or other components are connected directly:**
Example: Rotary SW on External Input and Output PCB is set to "1".

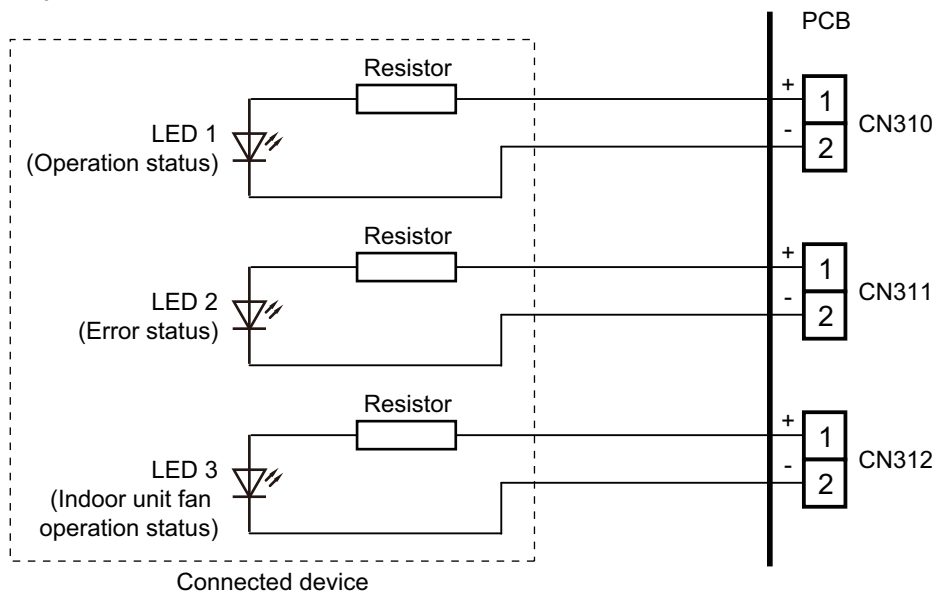

- **When connecting with a device equipped with a power supply:**
Example: Rotary SW on External Input and Output PCB is set to "1".

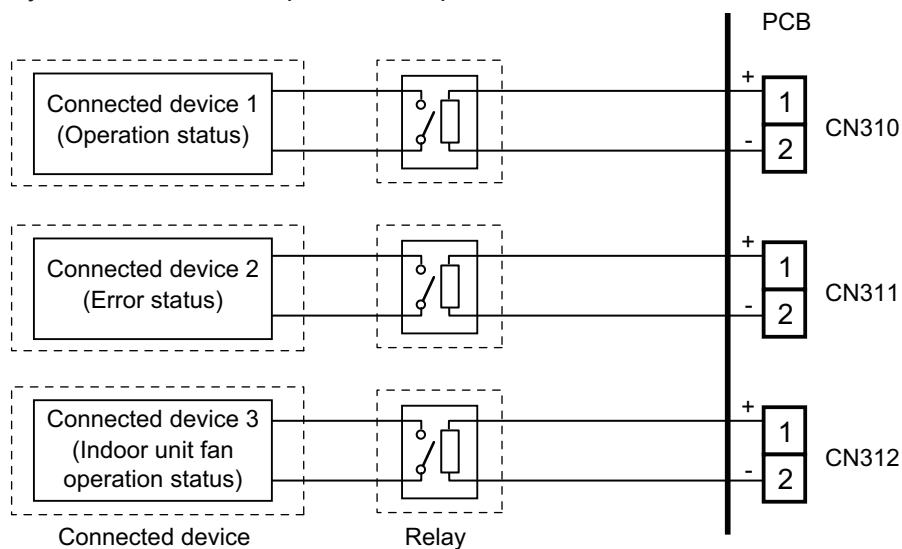

9-3. Setting of external input and output

- Indoor unit

Input		
Connection point	Function setting number 46	Function
CN46	00	Operation/Stop mode 1 (R.C. enabled)
	01	(Setting prohibited)
	02	Forced stop mode
	03	Operation/Stop mode 2 (R.C. disabled)

Output		
Connection point	Function setting number 60	Function
CN47	00	Operation/Stop
	01 to 08	(Setting prohibited)
	09	Error status
	10	Indoor unit fan operation status
	11	(Setting prohibited)

- External Input and Output PCB

Switch setting		Input		Output		
Rotary switch	SW302	CN313	CN314	CN310	CN311	CN312
1	Edge	Operation/Stop	Not available	Operation/Stop	Error status	Indoor unit fan operation status
	Pulse	Operation	Stop			
2	Edge*	Forced thermostat off	Not available	Error status	Indoor unit fan operation status	Not available
3 to 9, A		(Setting prohibited)				
B		Forced thermostat off	Not available	Operation/Stop	Indoor unit fan operation status	Not available
C		Forced thermostat off	Not available	Operation/Stop	Error status	Not available
D		Forced thermostat off	Not available	Operation/Stop	Indoor unit fan operation status	Error status

NOTES:

- When the rotary switch is selected to "1", the operation of the connector input of the indoor unit and the External Input and Output PCB input are the same. The operation content depends on the setting of function setting number 46.
- *: The external input other than "Operation/Stop" is available only when the SW302 is set to "Edge".

9-4. Details of control input function

■ Operation/Stop mode 1

- In the case of "Edge" input

Function setting	External Input and Output PCB		External input	Input signal	Command
	Rotary switch	SW302			
46-00	—		Input of indoor unit	CN46	Off → On Operation
	—		Input of indoor unit	CN46	On → Off Stop
	1	Edge	External Input and Output PCB	CN313	Off → On Operation
					On → Off Stop

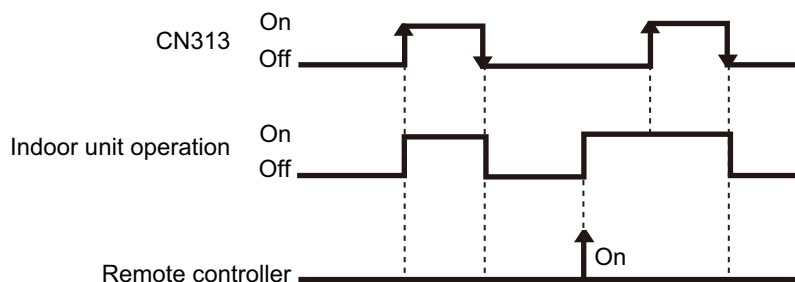

- In the case of "Pulse" input

Function setting	External Input and Output PCB		External input	Input signal	Command
	Rotary switch	SW302			
46-00	1	Pulse	External Input and Output PCB	CN313	Operation
				CN314	Stop

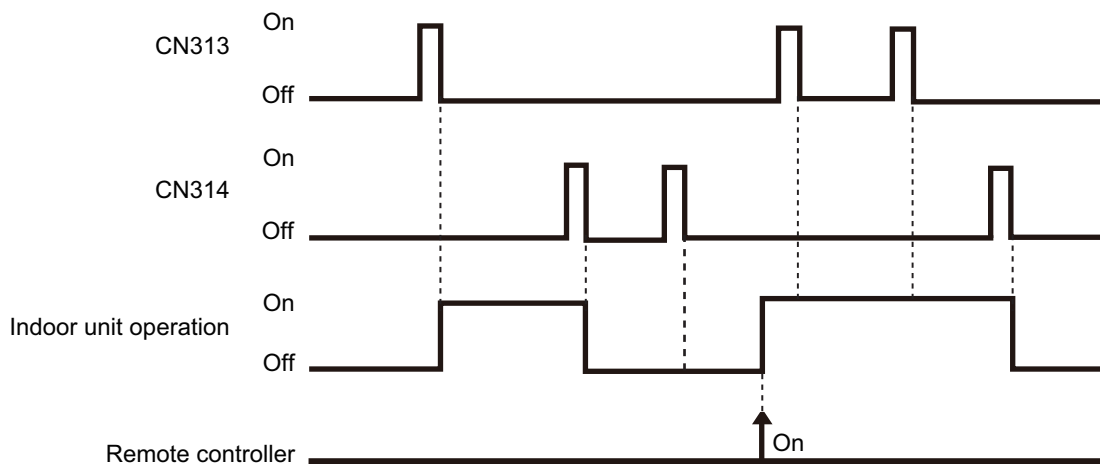

NOTES:

- The last command has priority.
- The indoor units within the same remote controller group operates in the same mode.

■ Forced stop

- In the case of "Edge" input

Function setting	External Input and Output PCB		External input		Input signal	Command
	Rotary switch	SW302				
46-02	—		Input of indoor unit	CN46	Off → On	Forced stop (R.C. disabled)
					On → Off	Normal (R.C. enabled)
	1	Edge	External Input and Output PCB	CN313	Off → On	Forced stop (R.C. disabled)
					On → Off	Normal (R.C. enabled)

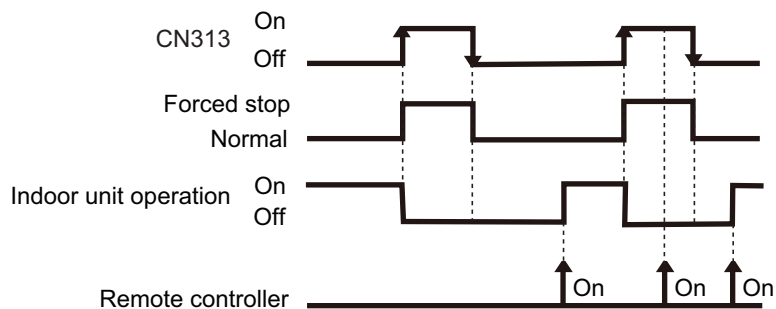

- In the case of "Pulse" input

Function setting	External Input and Output PCB		External input		Input signal	Command
	Rotary switch	SW302				
46-02	1	Pulse	External Input and Output PCB	CN313	Pulse	Forced stop (R.C. disabled)
				CN314		Normal (R.C. enabled)

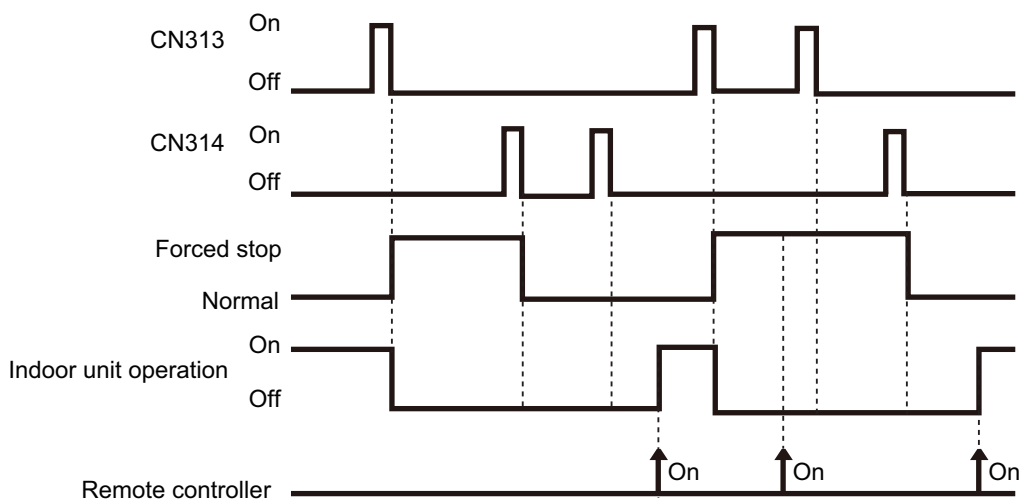

NOTES:

- When the forced stop is triggered, indoor unit stops and Operation/Stop operation by the remote controller is restricted.
- When forced stop function is used with forming a remote controller group, connect the same equipment to each indoor unit within the group.

■ Operation/Stop mode 2

- In the case of “Edge” input

Function setting	External Input and Output PCB		External input		Input signal	Command
	Rotary switch	SW302				
46-03	—		Input of indoor unit	CN46	Off → On	Operation (R.C. enabled)
					On → Off	Stop (R.C. disabled)
	1	Edge	External Input and Output PCB	CN313	Off → On	Operation (R.C. enabled)
					On → Off	Stop (R.C. disabled)

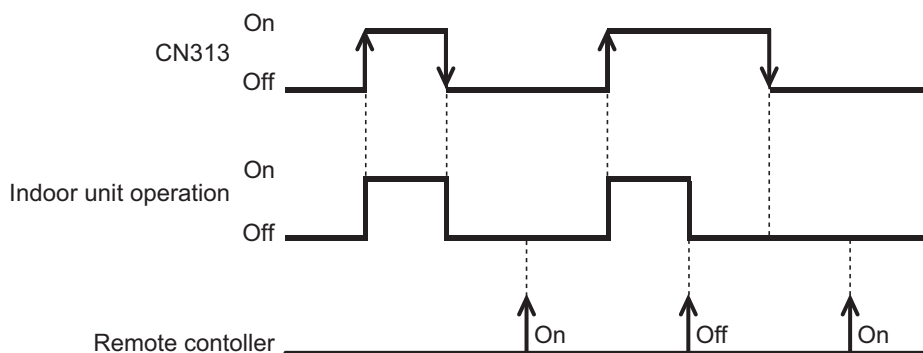

- In the case of “Pulse” input

Function setting	External Input and Output PCB		External input		Input signal	Command
	Rotary switch	SW302				
46-03	1	Pulse	External Input and Output PCB	CN313	Pulse	Operation (R.C. enabled)
				CN314		Stop (R.C. disabled)

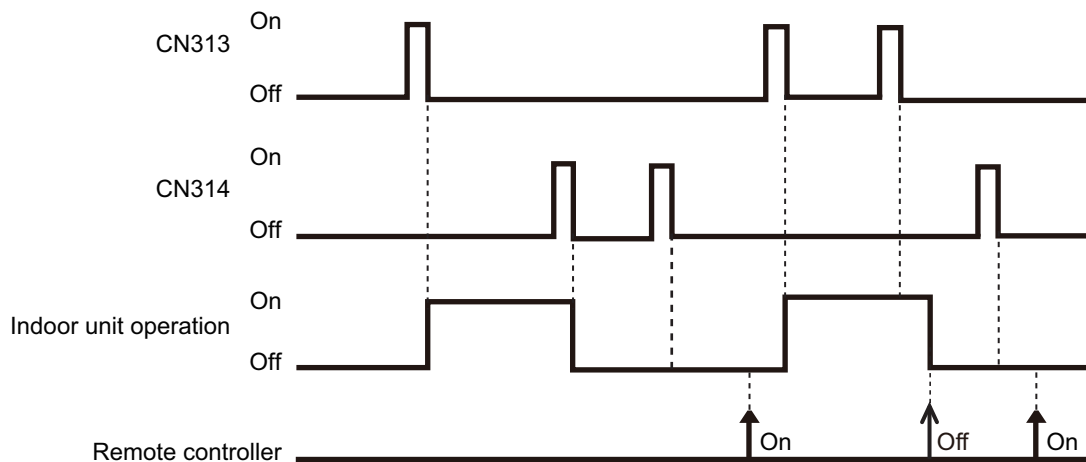

NOTE: When “Operation/Stop” mode 2 function is used with forming a remote controller group, connect the same equipment to each indoor unit within the group.

■ Forced thermostat off

External Input and Output PCB	External input		Input signal	Command
Rotary switch				
2, B, C, D	External Input and Output PCB	CN313	Off → On	Thermostat off
			On → Off	Normal operation

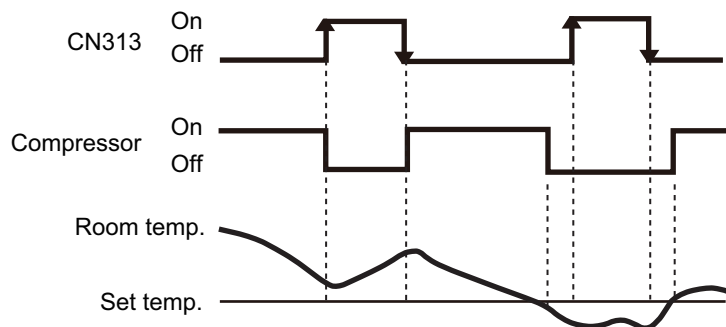

9-5. Details of control output function

■ Operation status

Function setting	External Input and Output PCB	External output		Output signal	Status
	Rotary switch				
60-00	1, 2	Output of indoor unit	CN47	Off → On	Operation
				On → Off	Stop
—	1, B, C, D	External Input and Output PCB	CN310	Off → On	Operation
				On → Off	Stop

The output is low when the unit is stopped.

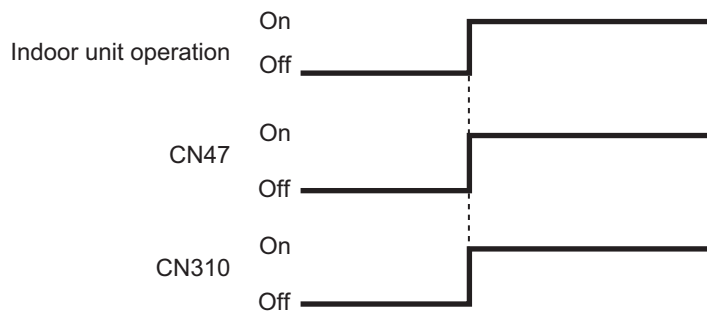

■ Error status

Function setting	External Input and Output PCB	External output		Output signal	Status
	Rotary switch				
60-09	—	Output of indoor unit	CN47	Off → On	Error
				On → Off	Normal
—	2	External Input and Output PCB	CN310	Off → On	Error
				On → Off	Normal
—	1, C	External Input and Output PCB	CN311	Off → On	Error
				On → Off	Normal
—	D	External Input and Output PCB	CN312	Off → On	Error
				On → Off	Normal

The output is on when an error is generated for the indoor unit.

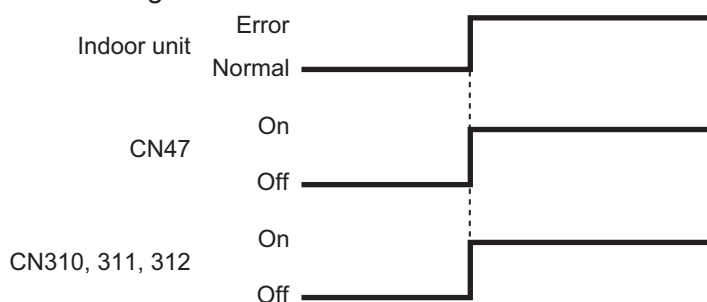

■ Indoor unit fan operation status

Function setting	External Input and Output PCB	External output		Output signal	Status
	Rotary switch				
60-10	C	Output of indoor unit	CN47	Off → On	Fan run
				On → Off	Fan stop
—	2, B, D	External Input and Output PCB	CN311	Off → On	Fan run
				On → Off	Fan stop
—	1	External Input and Output PCB	CN312	Off → On	Fan run
				On → Off	Fan stop

Output signal	Condition
On	The indoor unit fan is operating.
Off	The fan is stopped or during cold air prevention. During thermostat off when in dry mode operation.

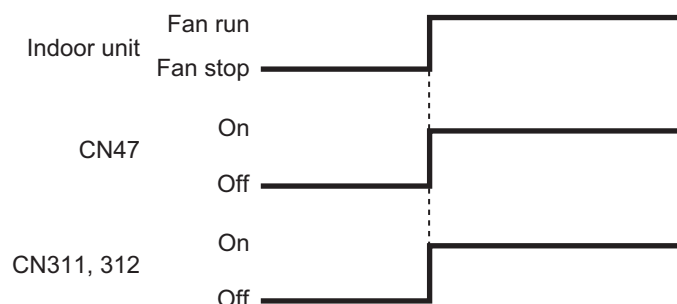

10. Group connection

NOTE: Group control cannot be used together with WLAN Adapter.

Installation procedure for group control system:

A number of indoor units can be operated at the same time using a single remote controller.

NOTE: When different type of indoor units (such as wall-mounted type and cassette type, cassette type and duct type, or other combinations) are connected using group control system, some functions may no longer be available.

1. Connect up to 16 indoor units in a system.

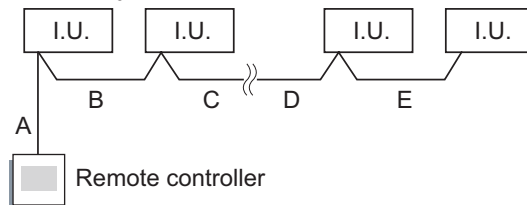

A, B, C, D, E: Remote controller cable		
Wiring length limitation	UTY-RVRY	$A + B + C + D + E \leq 70 \text{ m}$
	Other than UTY-RVRY	$A + B + C + D + E \leq 500 \text{ m}$

Example of wiring method

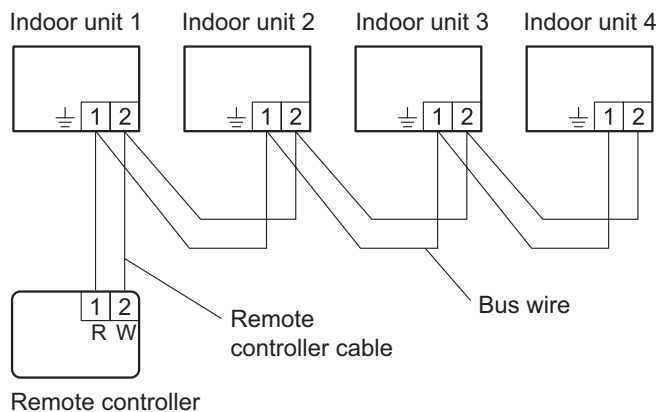

2. Automatic address setting

After the remote controller connection in the system, the automatic address setting runs in the initial starting up. Do not change the remote controller address for the indoor unit.

11. Remote controller

11-1. Wireless remote controller

Overview

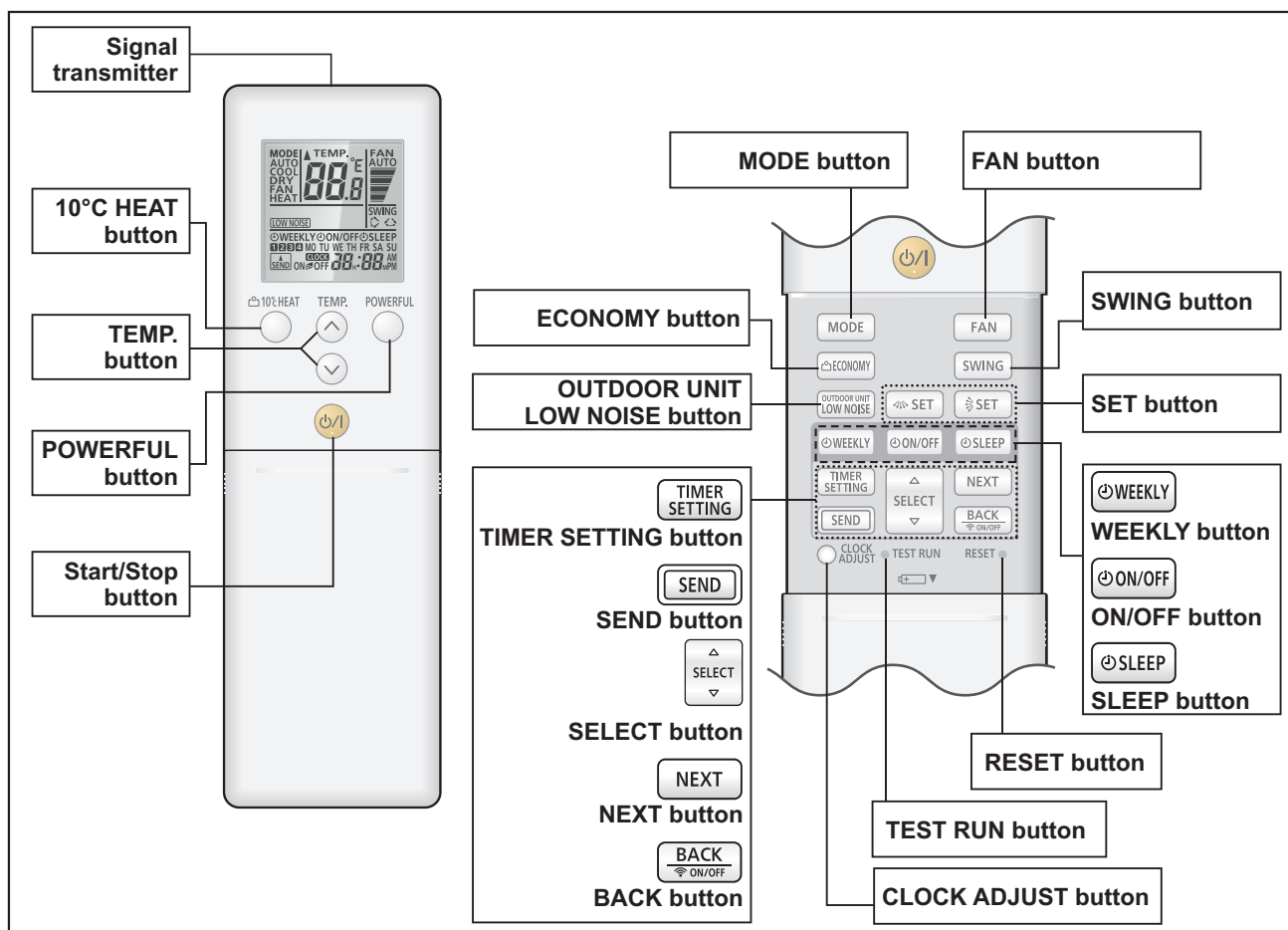

NOTE: Functions may differ by type of the indoor unit. For details, refer to the operation manual.

Display panel

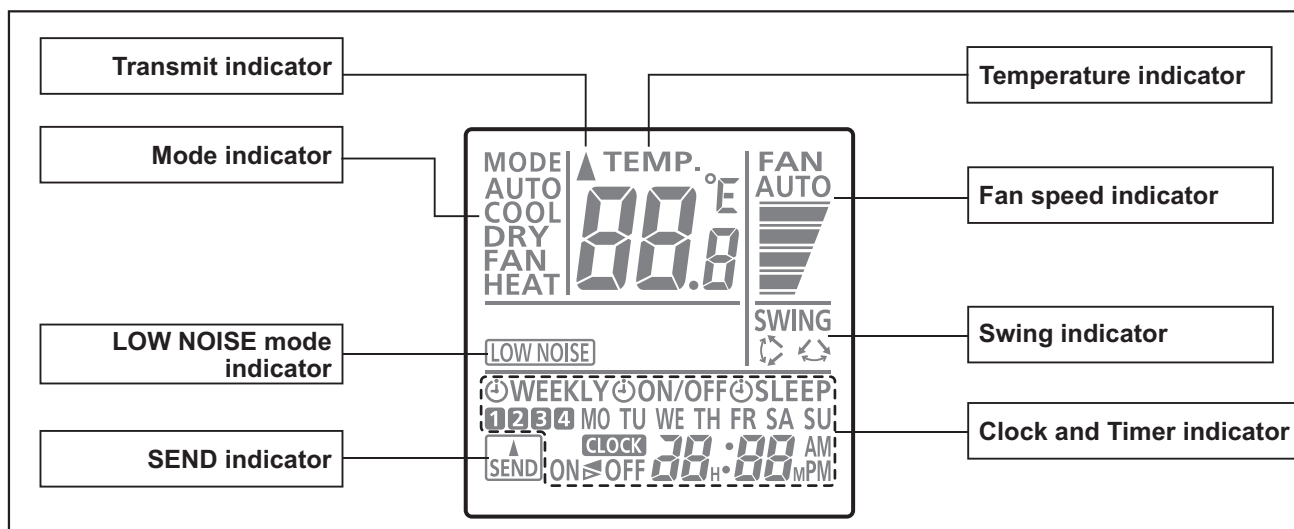

To facilitate explanation, the accompanying illustration has been drawn to show all possible indicators; in actual operation, however, the display will only show those indicators appropriate to the current operation.

Specifications

● Controller

Unit: mm

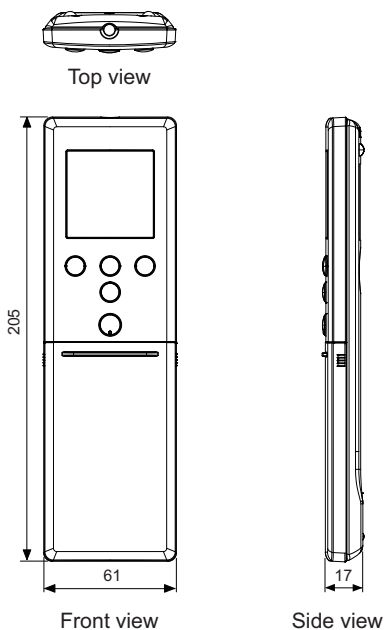

Size (H × W × D)	mm	205 × 61 × 17
Weight	g	125 (without batteries)

● Holder

Unit: mm

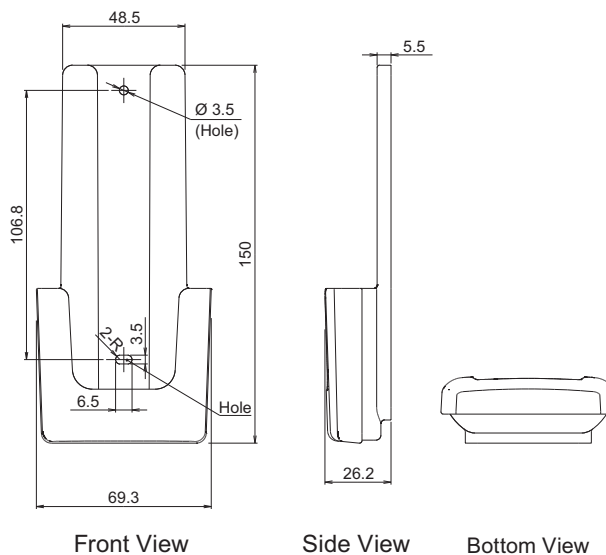

Size (H × W × D)	mm	150 × 69.3 × 26.2
Weight	g	27

12. Function settings

To adjust the functions of this product according to the installation environment, various types of function settings are available.

NOTE: Incorrect settings can cause a product malfunction.

12-1. Function settings by using remote controller

Some function settings can be changed on the remote controller. After confirming the setting procedure and the content of each function setting, select appropriate functions for your installation environment.

■ Setting procedure by using wireless remote controller

The function number and the associated setting value are displayed on the LCD of the remote controller. Follow the instructions written in the local setup procedure supplied with the remote controller, and select appropriate setting according to the installation environment.

Before connecting the power supply of the indoor unit, reconfirm following items:

- Cover for the electrical enclosure on the outdoor unit is in place.
- There is no wiring mistake.
- Piping air tightness test and vacuuming have been performed firmly.
- All the necessary wiring work for outdoor unit has been finished.

After reconfirming the items listed above, connect the power supply of the indoor unit.

NOTES:

- Settings will not be changed if invalid numbers or setting values are selected.
- When optional wired remote controller is used, refer to the installation manual enclosed with the remote controller.

Entering function setting mode:

While pressing the POWERFUL button and TEMP. (^) button simultaneously, press the RESET button to enter the function setting mode.

Selecting the function number and setting value:

1. Press the TEMP. (^) (v) buttons to select the function number. To switch between the left and right digits, press the 10 °C HEAT button.
2. Press the POWERFUL button to proceed to value setting. To return the function number selection, press the POWERFUL button again.
3. Press the TEMP. (^) (v) buttons to select the setting value. To switch between the left and right digits, press the 10 °C HEAT button.
4. Press the MODE button once. Confirm that you hear the beep.
5. Press the START/STOP button to fix the function setting. Confirm that you hear the beep.
6. Press the RESET button to end the function setting mode.
7. After completing the function setting, be sure to disconnect the power supply and then reconnect it.

Function number
Setting value



⚠ CAUTION

After disconnecting the power supply, wait 30 seconds or more before reconnecting it. The function setting will not become active unless the power supply is disconnected and then reconnected.

NOTES:

- The air conditioner custom code is set to \overline{H} prior to shipment.
- If you do not know the air conditioner custom code setting, try each of the custom codes ($\overline{H} \rightarrow \overline{b}$ $\rightarrow \overline{c} \rightarrow \overline{d}$) until you find the code that operates the air conditioner.

■ Contents of function setting

Each function setting listed in this section is adjustable in accordance with the installation environment.

NOTE: Setting will not be changed if invalid numbers or setting values are selected.

● Function setting list

	Function no.	Functions
1)	11	Filter sign
2)	30/31	Room temperature control for indoor unit sensor
3)	35/36	Room temperature control for wired remote controller sensor
4)	40	Auto restart
5)	42	Room temperature sensor switching
6)	44	Remote controller custom code
7)	46	External input control
8)	48	Room temperature sensor switching (Aux.)
9)	49	Indoor unit fan control for energy saving for cooling
10)	60	Switching functions for external output terminal
11)	84	Wired Remote Controller function extension setting

1) Filter sign

Select appropriate intervals for displaying the filter sign on the indoor unit according to the estimated amount of dust in the air of the room.

If the indication is not required, select "No indication" (03).

Function number	Setting value	Setting description	Factory setting
11	00	Standard (400 hours)	
	01	Long interval (1,000 hours)	
	02	Short interval (200 hours)	
	03	No indication	◆

2) Room temperature control for indoor unit sensor

Depending on the installed environment, correction of the room temperature sensor may be required. Select the appropriate control setting according to the installed environment.

The temperature of the room temperature sensor is corrected as follows:

Corrected temp. = Temp. of the room temp. sensor - Correction temp. value

Example of correction:

When the temperature of the room temp. sensor is 26°C and the setting value is "03" (-1.0°C), corrected temp. will be 27°C (26°C - [-1.0°C]).

The temperature correction values show the difference from the Standard setting "00" (manufacturer's recommended value).

Function number		Setting value	Setting description	Factory setting	
30 (For cooling)	31 (For heating)	00	Standard setting	◆	
		01	No correction 0.0°C		
		02	-0.5°C	More cooling Less heating	
		03	-1.0°C		
		04	-1.5°C		
		05	-2.0°C		
		06	-2.5°C		
		07	-3.0°C		
		08	-3.5°C		
		09	-4.0°C		
		10	+0.5°C	Less cooling More heating	
		11	+1.0°C		
		12	+1.5°C		
		13	+2.0°C		
		14	+2.5°C		
		15	+3.0°C		
		16	+3.5°C		
17	+4.0°C				

3) Room temperature control for wired remote controller sensor

Depending on the installed environment, correction of the wire remote temperature sensor may be required. Select the appropriate control setting according to the installed environment.

To change this setting, set Function 42 to Both "01".

Ensure that the Thermo Sensor icon is displayed on the remote controller screen.

Function number		Setting value	Setting description	Factory setting	
35 (For cooling)	36 (For heating)	00	Standard setting	◆	
		01	No correction 0.0°C		
		02	-0.5°C	More cooling Less heating	
		03	-1.0°C		
		04	-1.5°C		
		05	-2.0°C		
		06	-2.5°C		
		07	-3.0°C		
		08	-3.5°C		
		09	-4.0°C		
		10	+0.5°C	Less cooling More heating	
		11	+1.0°C		
		12	+1.5°C		
		13	+2.0°C		
		14	+2.5°C		
		15	+3.0°C		
		16	+3.5°C		
17	+4.0°C				

4) Auto restart

Enables or disables automatic restart after a power interruption.

Function number	Setting value	Setting description	Factory setting
40	00	Enable	◆
	01	Disable	

NOTE: Auto restart is an emergency function such as for power outage etc. Do not attempt to use this function in normal operation. Be sure to operate the unit by remote controller or external device.

5) Room temperature sensor switching

(Only for wired remote controller)

When using the wired remote controller temperature sensor, change the setting to "Both" (01).

Function number	Setting value	Setting description	Factory setting
42	00	Indoor unit	◆
	01	Both	

00: Sensor on the indoor unit is active.

01: Sensors on both indoor unit and wired remote controller are active.

NOTE: Remote controller sensor must be turned on by using the remote controller.

6) Remote controller custom code

(Only for wireless remote controller)

The indoor unit custom code can be changed. Select the appropriate custom code.

Function number	Setting value	Setting description	Factory setting
44	00	A	◆
	01	B	
	02	C	
	03	D	

7) External input control

“Operation/Stop” mode or “Forced stop” mode can be selected.

Function number	Setting value	Setting description	Factory setting
46	00	Operation/Stop mode 1 (Remote controller enabled)	◆
	01	(Setting prohibited)	
	02	Forced stop mode	
	03	Operation/Stop mode 2 (Remote controller disabled)	

8) Room temperature sensor switching (Aux.)

To use the temperature sensor on the wired remote controller only, change the setting to “Wired remote controller” (01).

This function will only work if the function setting 42 is set at “Both” (01).

When the setting value is set to “Both” (00), more suitable control of the room temperature is possible by setting function setting 30 and 31 too.

Function number	Setting value	Setting description	Factory setting
48	00	Both	◆
	01	Wired remote controller	

9) Indoor unit fan control for energy saving for cooling

Enables or disables the power-saving function by controlling the indoor unit fan rotation when the outdoor unit is stopped during cooling operation.

Function number	Setting value	Setting description	Factory setting
49	00	Disable	
	01	Enable	
	02	Remote controller	◆

00: When the outdoor unit is stopped, the indoor unit fan operates continuously following the setting on the remote controller.

01: When the outdoor unit is stopped, the indoor unit fan operates intermittently at a very low speed.

02: Enable or disable this function by remote controller setting.

NOTE: Set to “00” or “01” when connecting a remote controller that cannot set the Fan control for energy saving function or connecting a network converter. To confirm if the remote controller has this setting, refer to the operating manual of each remote controller.

10) Switching functions for external output terminal

Functions of the external output terminal can be switched. For details, refer to “External input and output”.

Function number	Setting value	Setting description	Factory setting
60	00	Operation status	◆
	01—08	(Setting prohibited)	
	09	Error status	
	10	Indoor unit fan operation status	
	11	(Setting prohibited)	

11) Wired Remote Controller function extension setting

Enables the Powerful, 10°C Heat, or Outdoor Unit Low Noise operation when connecting the Wired Remote Controller (UTY-RVRY).

Function number	Setting value	Setting description	Factory setting
84	00	Disable	◆
	01	Enable	

- Refer to the operation manual of the air conditioner to check whether it supports each function.
- All indoor units must have the same setting value in a Group Control system.

12-2. Custom code setting for wireless remote controller

To interconnect the air conditioner and the wireless remote controller, assignment of the custom code for the wireless remote controller is required.

NOTE: Air conditioner cannot receive a signal if the air conditioner has not been set for the custom code.

When 2 or more air conditioners are installed in a room, and the remote controller is operating an air conditioner other than the one you wish to set, change the custom code of the remote controller to operate only the air conditioner you wish to set. (4 selections possible.)

Confirm the setting of the remote controller custom code and the function setting. If these do not match, the remote controller cannot be used to operate for the air conditioner.

1. Press the START/STOP button until only the clock is displayed on the remote controller display.
2. Press the MODE button for at least 5 seconds to display the current custom code. (Initially set to H .)
3. Press the TEMP. (\wedge) (\vee) buttons to change the custom code between $\text{H} \rightarrow \text{b} \rightarrow \text{c} \rightarrow \text{d}$. Match the code on the display to the air conditioner custom code. (Initially set to H .)
4. Press the MODE button again to return to the clock display. The custom code will be changed.











NOTES:

- If you do not press the button for 30 seconds, the displayed custom code will be set.
- The air conditioner custom code is set to H prior to shipment. To change the custom code, contact your retailer.
- If you do not know the assigned code for the air conditioner, try each of the custom code ($\text{H} \rightarrow \text{b} \rightarrow \text{c} \rightarrow \text{d}$) until you find the code which operates the air conditioner.

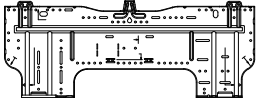
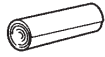

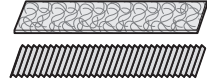
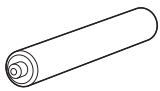
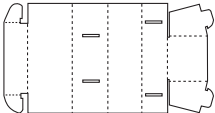

13. Accessories

13-1. Models: ASEH18KMTGL and ASEH24KMTGL

Part name	Exterior	Qty	Part name	Exterior	Qty
Operation manual		1	Self-tapping screw (large)		5
Installation manual		1	Self-tapping screw (small)		2
Wall hook bracket		1	Cloth tape		1
Remote controller		1	Filter holder		2
Remote controller holder		1	Air cleaning filters		1
Battery		2	Installation spacer		1

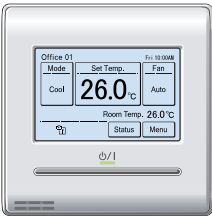
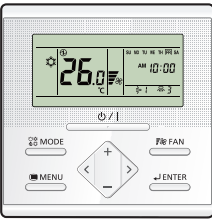
14. Optional parts

14-1. Controllers







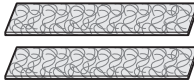
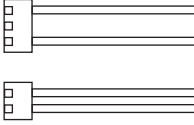
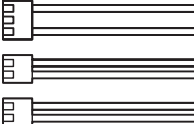

Exterior	Part name	Model name	Summary
	Wired Remote Controller (Touch Panel)	UTY-RVRY	Remote controller that provides the functions you need in a sleek design that uniquely transforms itself to blend with any interior. Optional Communication Kit is necessary for installation.
	Wired Remote Controller (Touch Panel)	UTY-RNRYZ*	Easy finger touch operation with LCD panel. Backlit LCD enables easy operation in a dark room. Optional Communication Kit is necessary for installation.
	Wired Remote Controller	UTY-RLRY	High visibility and easy operation. Room temperature can be accurately controlled using the thermo sensor. Optional Communication Kit is necessary for installation.
	Compact Wired Remote Controller	UTY-RCRYZ1	Compact body and easy operation. Room temperature can be accurately controlled using the thermo sensor. Optional Communication Kit is necessary for installation.
	Simple Remote Controller	UTY-RSRY UTY-RSRYZ*	Compact remote controller concentrates on the basic functions such as Start/ Stop, fan control, temperature setting, and operation mode. Optional Communication Kit is necessary for installation.
	Simple Remote Controller	UTY-RHRY UTY-RHRYZ*	Compact remote controller concentrates on the basic functions such as Start/ Stop, fan control, and temperature setting. Optional Communication Kit is necessary for installation.

Exterior	Part name	Model name	Summary
	<p>Wireless Remote Controller</p>	<p>UTY-LNWX</p>	<p>Unit control is performed by Wireless Remote Controller.</p>

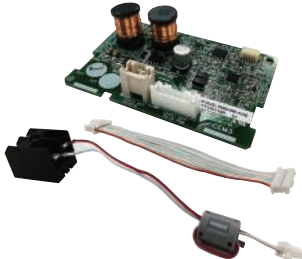
NOTES:

- Available functions may differ by the remote controller. For details, refer to the operation manual.
- When using the group controlling system of the Wired Remote Controller, using WLAN Adapter is prohibited.

14-2. Others

Exterior	Part name	Model name	Summary
	Air Cleaning Filter	UTR-FA16-5	Air Cleaning Filter can be mounted to the indoor unit. (For antibacterial)
	External Connect Kit	UTY-XWZX	Use to connect with various peripheral devices and air conditioner PCB. Connecting point: CN46 and CN47 on Main PCB
	External Connect Kit	UTY-XWZXZ5	Required when external device is connected. Connecting point: CN46 and CN47 on Main PCB
	External Input and Output PCB	UTY-XCSXZ2	Use to connect with external devices and air conditioner PCB. Optional External Connect Kit might be required to connect locally purchased devices via this PCB. Connecting point: CN65 on Main PCB
	Communication Kit	UTY-TWRXZ2	Use to connect Non-polar 2-core wired remote controller. Connecting point: CN13 on Main PCB
	Modbus Converter	UTY-VMSX	For connection between indoor unit with UART interface and a Modbus open network. Connecting point: CN65 on Main PCB
	KNX Converter	UTY-VKSX	For connection between indoor unit with UART interface and a KNX open network. Connecting point: CN65 on Main PCB
	Network Converter	UTY-VTGX	This converter is required when connecting single split system to VRF network system. Optional Communication Kit is necessary for installation.
	Network Converter (AC power supply)	UTY-VTGXV	This converter is required when connecting single split system to VRF network system. Optional Communication Kit is necessary for installation.
	External Switch Controller	UTY-TERX	Air conditioner switching can be controlled by connecting other external sensor switches. Optional Communication Kit is necessary for installation.

Part 2. OUTDOOR UNIT

SINGLE TYPE:

AOEH18KMTG

AOEH24KMTG

1. Specifications

OUTDOOR UNIT
AOEH18-24KMTG

OUTDOOR UNIT
AOEH18-24KMTG

Type			Inverter, Heat pump	
Model name			AOEH18KMTG	AOEH24KMTG
Power supply			230 V~ 50 Hz	
Power supply intake			Outdoor unit	
Available voltage range			198—264 V	
Starting current			A	
Fan	Airflow rate	Cooling	7.0	9.8
		Heating	2,350	3,240
	Type × Qty		2,100	2,970
	Motor output	W	Propeller fan × 1 49	
Sound pressure level*	Cooling	dB (A)	50	54
		Heating	50	54
Sound power level	Cooling	dB (A)	65	67
	Heating		65	67
Heat exchanger type	Dimensions (H × W × D)	mm	Main 1: 588 × 881 × 18.19	Main 1: 672 × 881 × 18.19
	Fin pitch		Main 2: 588 × 851 × 18.19	Main 2: 672 × 851 × 18.19
	Rows × Stages		Main 1: 1.3	Main 2: 1.3
	Pipe type		Main 1: 1 × 28	Main 1: 1 × 32
			Main 2: 1 × 28	Main 2: 1 × 32
	Fin type	Type (Material)	Copper tube	
	Surface treatment	Aluminum		
Compressor	Type		DC twin rotary	
	Motor output	W	900	1,060
Refrigerant	Type (Global warming potential)		R32 (675)	
	Charge	g	1,020	1,320
Refrigerant oil	Type		FW68S	RmM68AF
	Amount	cm ³	350	400
Enclosure	Material		Steel sheet	
	Color		Beige	
Dimensions (H × W × D)	Net	mm	632 × 799 × 290	716 × 820 × 315
	Gross		692 × 940 × 375	776 × 961 × 450
Weight	Net	kg	36	42
	Gross		40	47
Connection pipe	Size	Liquid	Ø6.35 (Ø1/4)	
		Gas	Ø12.70 (Ø1/2)	
	Method		Flare	
	Pre-charge length		15	
	Min. length	m	3	
	Max. length		25	30
Max. height difference	20		25	
Operation range	Cooling	°C	-10 to 50	
	Heating		-15 to 24	
Drain hose	Material		Polypropylene	
	Tip diameter	mm	Ø13.0 (I.D.), Ø16.0 to Ø16.7 (O.D.)	

NOTES:

- Specifications are based on the following conditions:
 - Cooling: Indoor temperature of 27°CDB/19°CWB, and outdoor temperature of 35°CDB/24°CWB.
 - Heating: Indoor temperature of 20°CDB/15°CWB, and outdoor temperature of 7°CDB/6°CWB.
 - Pipe length: 5.0 m, Height difference: 0 m. (Between outdoor unit and indoor unit.)
- Protective function might work when using it outside the operation range.
- *: Sound pressure level
 - Measured values in manufacturer's semi-anechoic chamber.
 - Because of the surrounding sound environment, the sound levels measured in actual installation conditions might be higher than the specified values here.

2. Dimensions

2-1. Model: AOEH18KMTG

Unit: mm

OUTDOOR UNIT
AOEH18-24KMTG

OUTDOOR UNIT
AOEH18-24KMTG

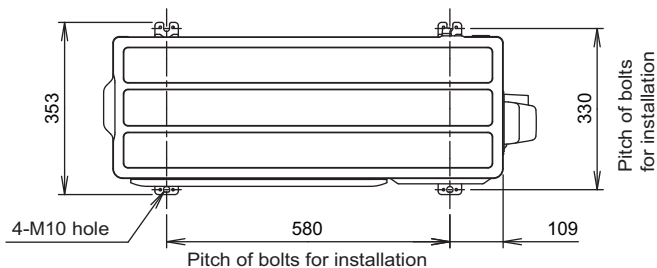

Top view

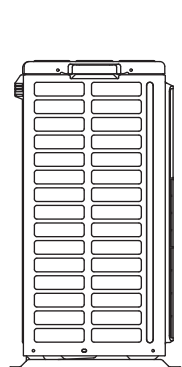

Side view

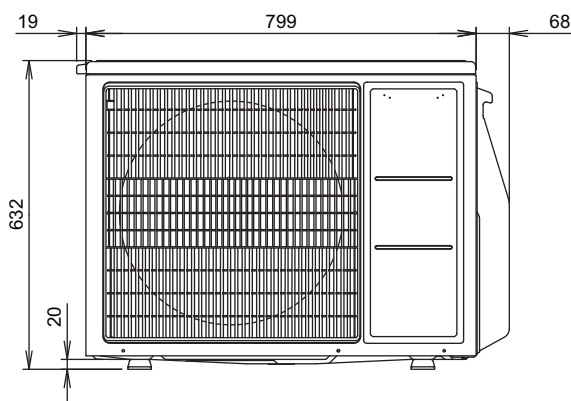

Front view

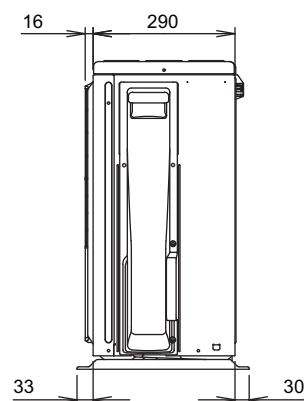

Side view

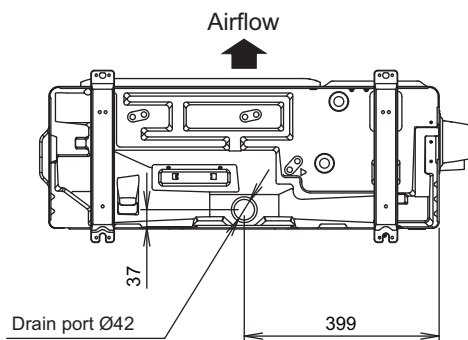

Bottom view

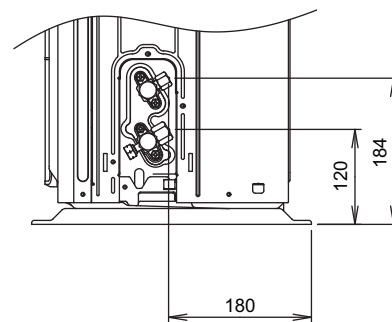

Side view (Valve part)

2-2. Model: AOEH24KMTG

Unit: mm

OUTDOOR UNIT
AOEH18-24KMTG

OUTDOOR UNIT
AOEH18-24KMTG

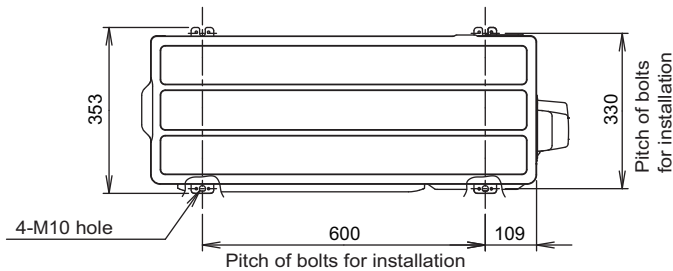

Top view

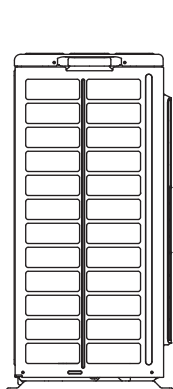

Side view

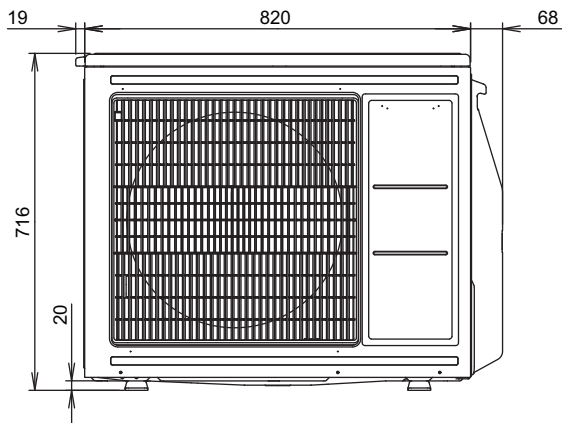

Front view

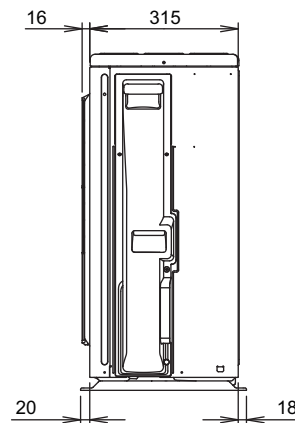

Side view

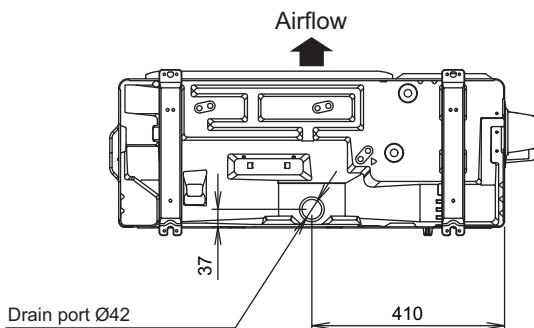

Bottom view

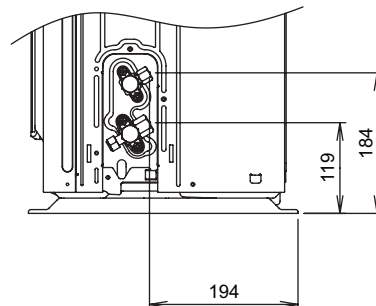

Side view (Valve part)

3. Installation space

3-1. Models: AOEH18KMTG and AOEH24KMTG

■ Space requirement

Provide sufficient installation space for product safety.

⚠ CAUTION

Keep the space shown in the installation examples.

If the installation is not performed accordingly, it could cause a short circuit and result in a lack of operating performance.

● Single outdoor unit installation

- When the upper space is open:

Unit: mm

Obstacles at rear only

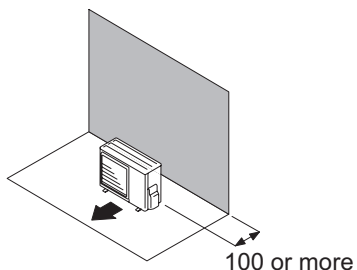

Obstacles at rear and sides

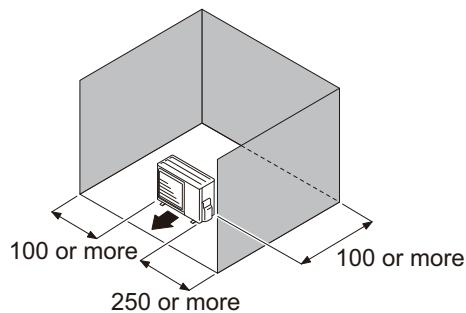

Obstacles at front

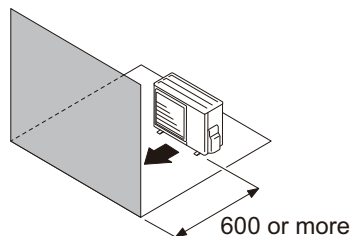

Obstacles at front and rear

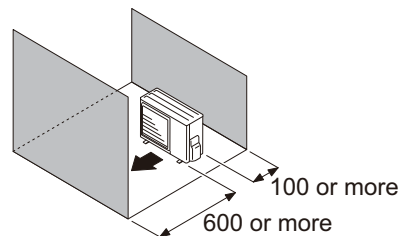

- When an obstruction in the upper space:

Unit: mm

Obstacles at rear and above

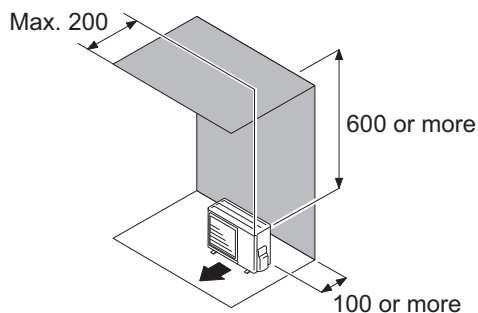

Obstacles at rear, sides, and above

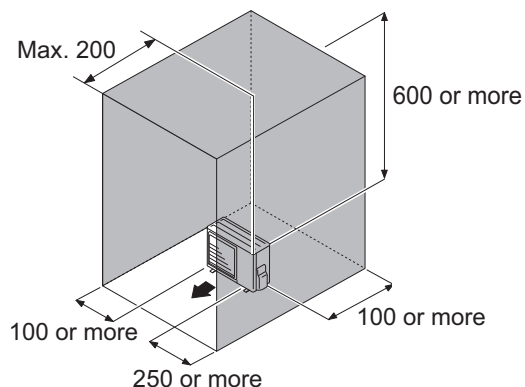

● Multiple outdoor unit installation

- Provide at least 250 mm of space between the outdoor units if multiple units are installed.
- When routing the piping from the side of an outdoor unit, provide space for piping.
- No more than 3 units must be installed side by side.
When 4 units or more are arranged in a line, provide the space as shown in the following example **“When an obstruction in the upper space:”**.

- **When the upper space is open:**

Unit: mm

Obstacles at rear only

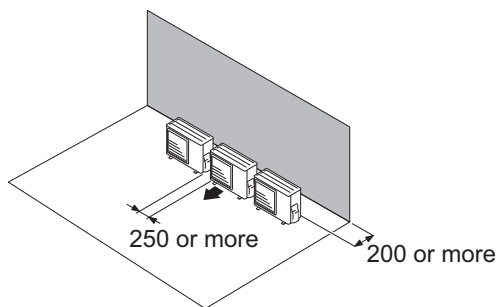

Obstacles at front only

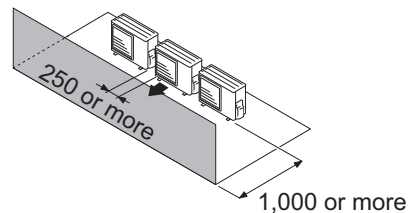

Obstacles at front and rear

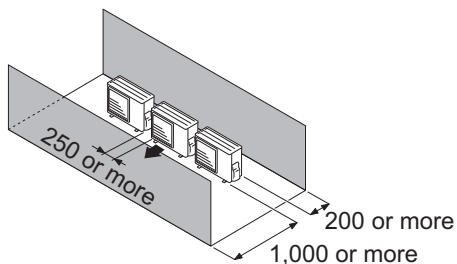

- **When an obstruction in the upper space:**

Unit: mm

Obstacles at rear and above.

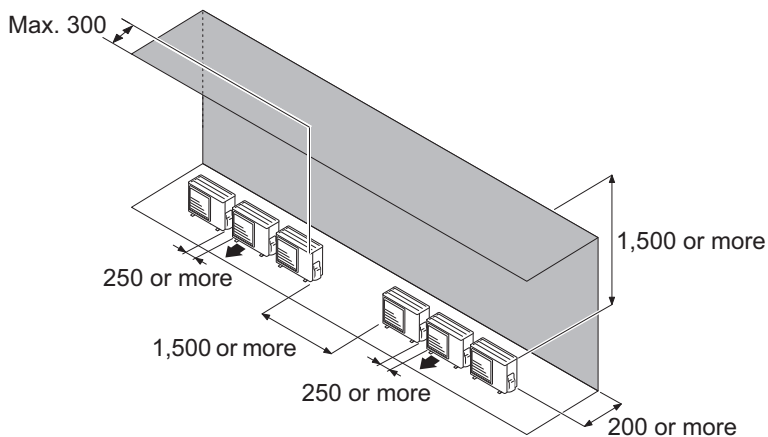

● Outdoor units installation in multi-row

Unit: mm

Single parallel unit arrangement

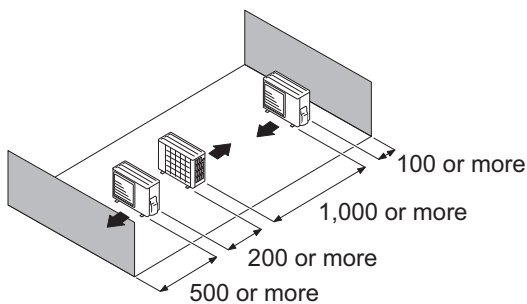

Multiple parallel unit arrangement

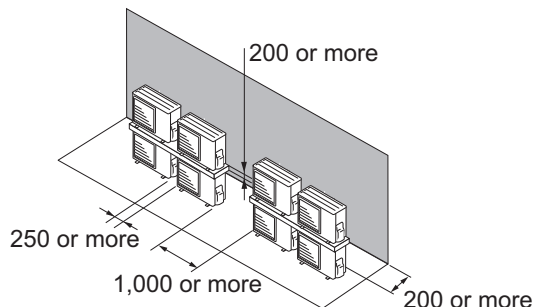
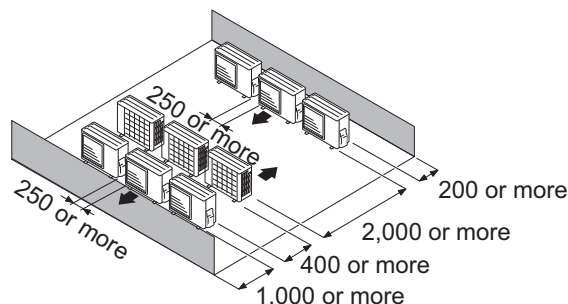

NOTES:

- If the space is larger than stated above, the condition will be the same as when there is no obstacle.
- When installing the outdoor unit, be sure to open the front and left side to obtain better operation efficiency.

⚠ CAUTION

- Do not install the outdoor unit in two-stage where the drain water could freeze. Otherwise the drainage from the upper unit may form ice and cause a malfunction of the lower unit.
- When the outdoor temperature is 0 °C or less, do not use the accessory drain pipe and drain cap. If the drain pipe and drain cap are used, the drain water in the pipe may freeze in extremely cold climate. (For reverse cycle model only.)
- In area with heavy snowfall, if the inlet and outlet of the outdoor unit is blocked with snow, it might become difficult to get warm, and it is likely to cause product malfunction. Construct a canopy and a pedestal, or place the unit on a high stand that is locally installed.

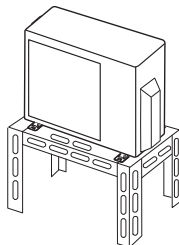

OUTDOOR UNIT
AOEH18-24KMTG

OUTDOOR UNIT
AOEH18-24KMTG

4. Refrigerant circuit

4-1. Model: AOEH18KMTG

OUTDOOR UNIT
AOEH18-24KMTG

OUTDOOR UNIT
AOEH18-24KMTG

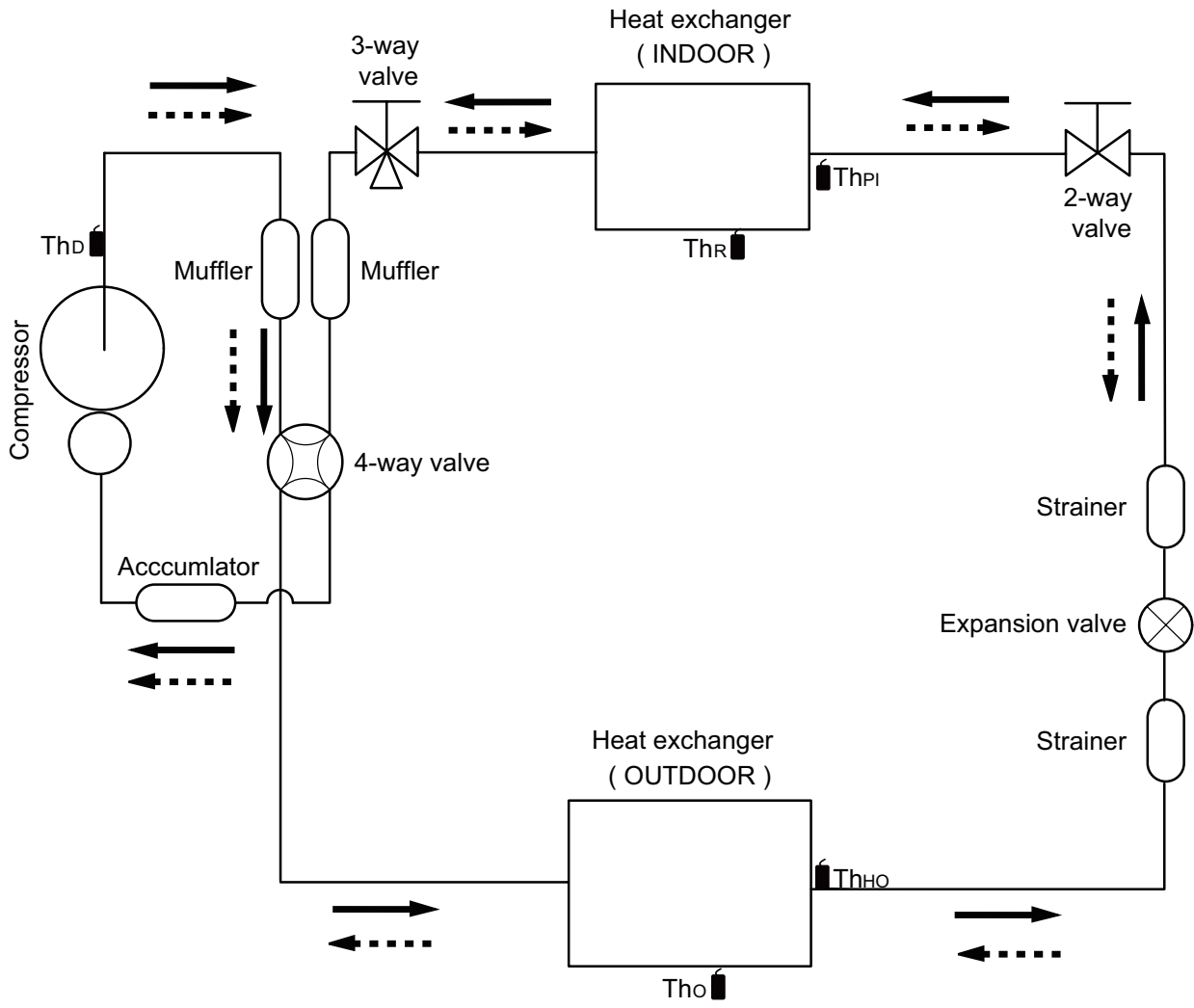

Cooling
 Heating

- Th_D : Thermistor (Discharge temperature)
- Th_O : Thermistor (Outdoor temperature)
- Th_{HO} : Thermistor (Heat exchanger out temperature)
- Th_{PI} : Thermistor (Pipe temperature)
- Th_R : Thermistor (Room temperature)

4-2. Model: AOEH24KMTG

OUTDOOR UNIT
AOEH18-24KMTG

OUTDOOR UNIT
AOEH18-24KMTG

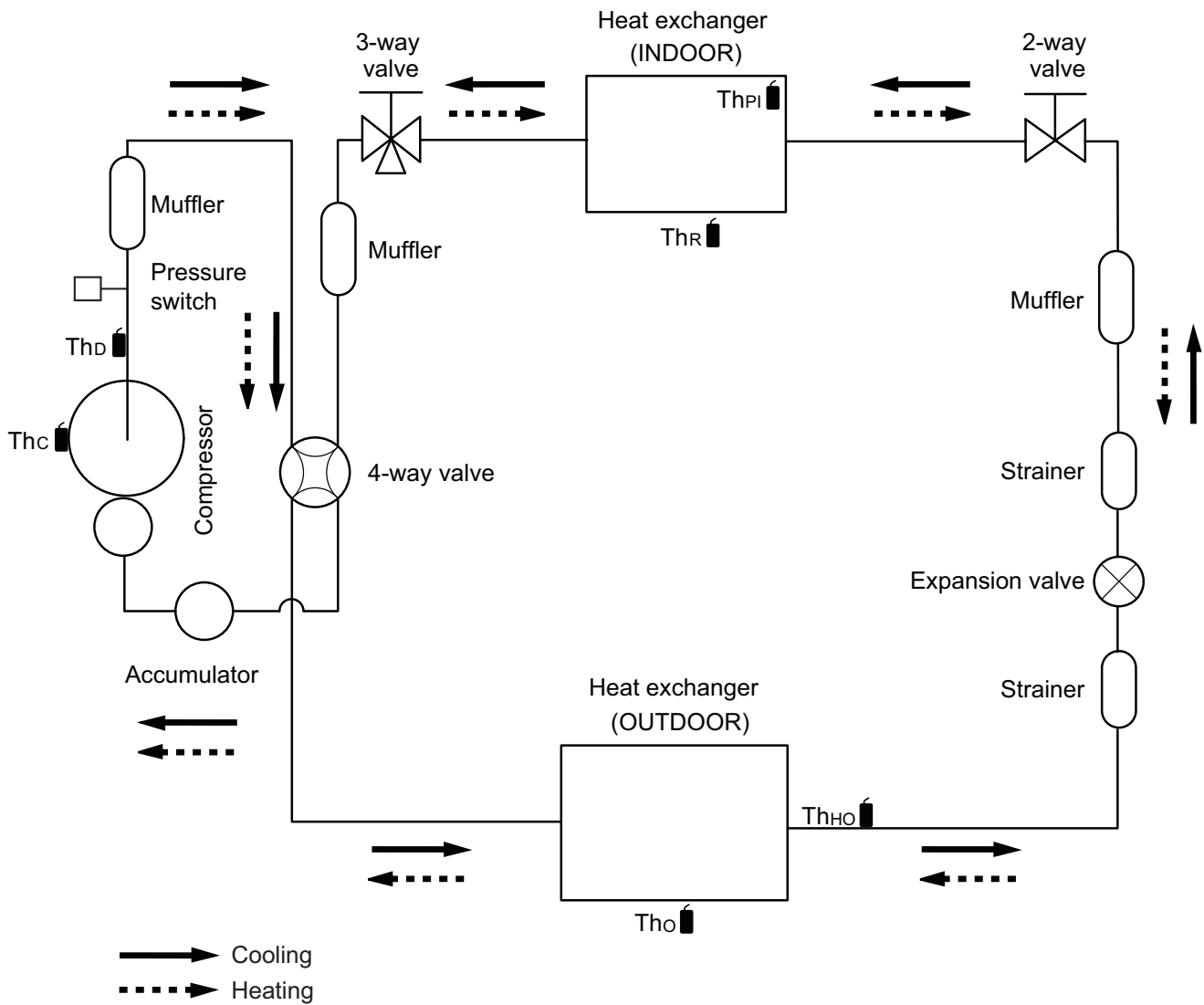

- Thc : Thermistor (Compressor temperature)
- Thd : Thermistor (Discharge temperature)
- Tho : Thermistor (Outdoor temperature)
- ThHo : Thermistor (Heat exchanger out temperature)
- ThPI : Thermistor (Pipe temperature)
- ThR : Thermistor (Room temperature)

5. Wiring diagrams

5-1. Model: AOEH18KMTG

OUTDOOR UNIT
AOEH18-24KMTG

OUTDOOR UNIT
AOEH18-24KMTG

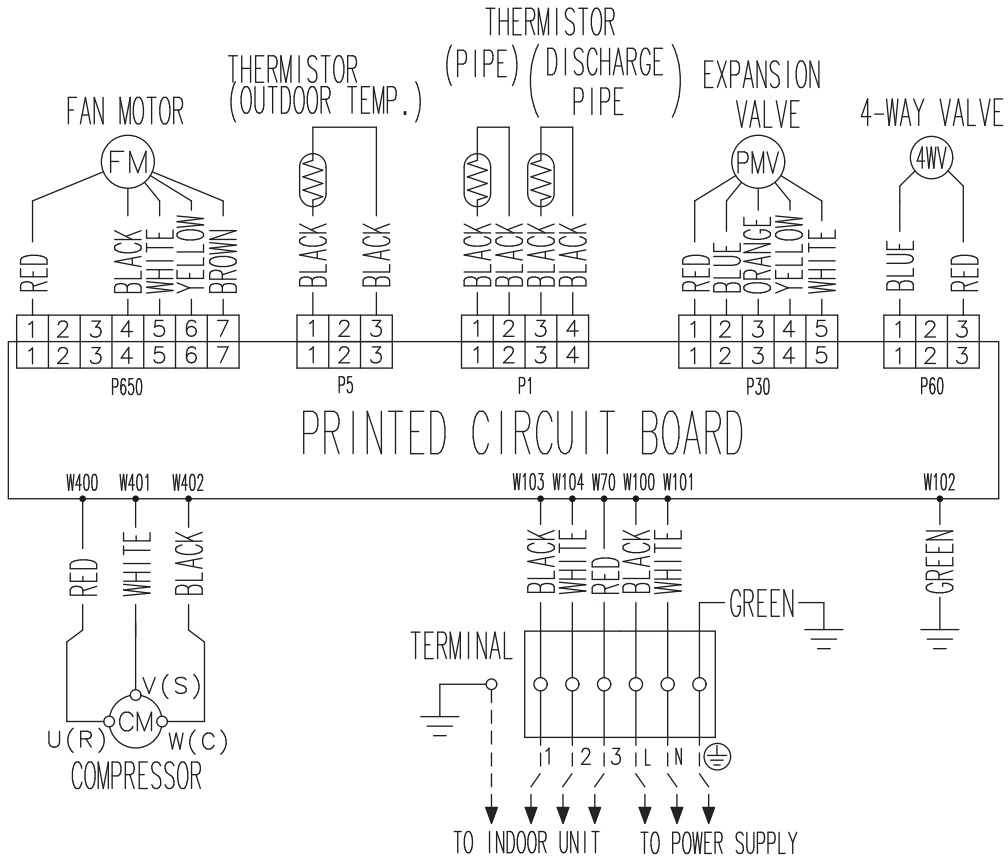

5-2. Model: AOEH24KMTG

OUTDOOR UNIT
AOEH18-24KMTG

OUTDOOR UNIT
AOEH18-24KMTG

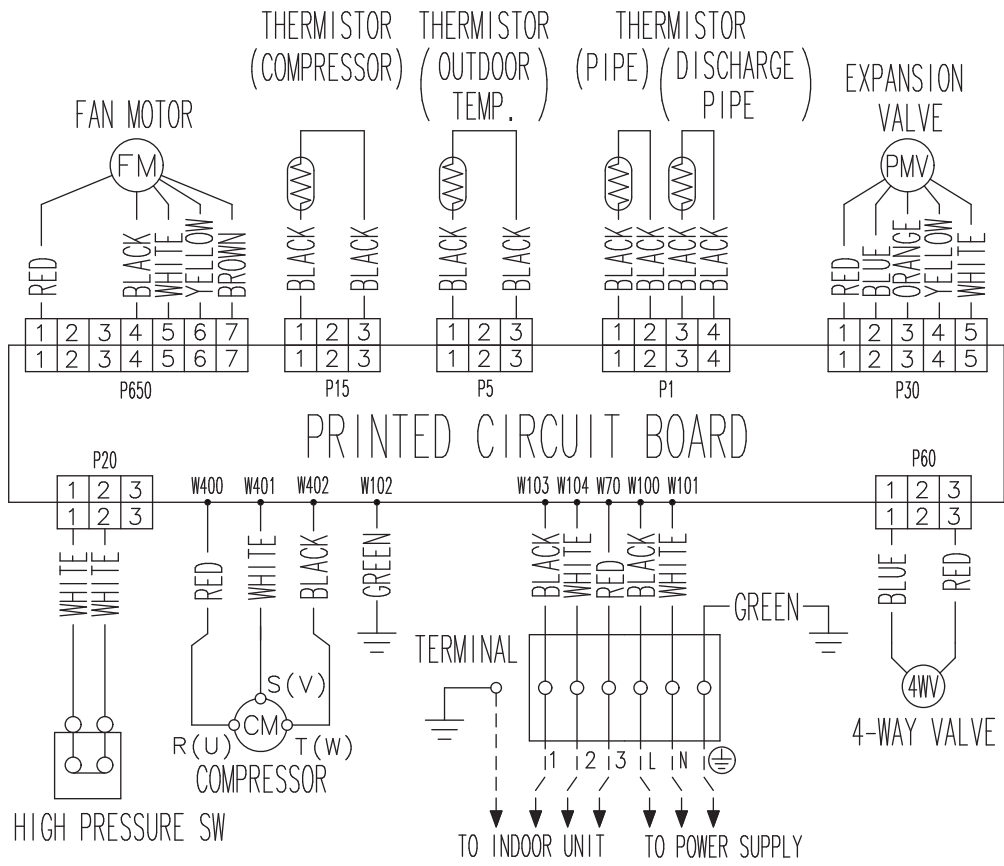

6. Capacity compensation rate for pipe length and height difference

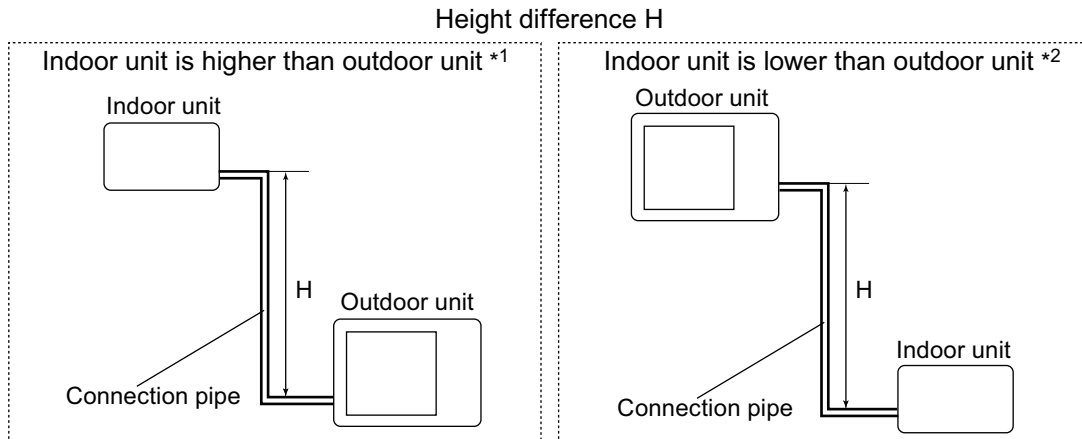

OUTDOOR UNIT
AOEH18-24KMTG

OUTDOOR UNIT
AOEH18-24KMTG

6-1. Model: AOE18KMTG

NOTE: Values mentioned in the table are calculated based on the maximum capacity.

COOLING			Pipe length (m)						
			3	5	7.5	10	15	20	25
Height difference H (m)	Indoor unit is higher than outdoor unit *1	20	—	—	—	—	—	0.917	0.900
		10	—	—	—	0.966	0.947	0.932	0.914
		7.5	—	—	0.979	0.970	0.951	0.936	0.918
		5	—	0.992	0.983	0.974	0.955	0.939	0.922
		3	1.003	0.995	0.986	0.977	0.958	0.945	0.928
	Indoor unit is lower than outdoor unit *2	0	1.008	1.000	0.991	0.981	0.963	0.946	0.930
		-3	1.008	1.000	0.991	0.981	0.963	0.946	0.930
		-5	—	1.000	0.991	0.981	0.963	0.946	0.930
		-7.5	—	—	0.991	0.981	0.963	0.946	0.930
		-10	—	—	—	0.981	0.963	0.946	0.930
		-20	—	—	—	—	0.963	0.946	0.930

HEATING			Pipe length (m)						
			3	5	7.5	10	15	20	25
Height difference H (m)	Indoor unit is higher than outdoor unit *1	20	—	—	—	—	—	0.887	0.871
		10	—	—	—	0.952	0.903	0.887	0.871
		7.5	—	—	0.976	0.952	0.903	0.887	0.871
		5	—	1.000	0.976	0.952	0.903	0.887	0.871
		3	1.024	1.000	0.976	0.952	0.903	0.887	0.871
	Indoor unit is lower than outdoor unit *2	0	1.024	1.000	0.976	0.952	0.903	0.887	0.871
		-3	1.021	0.997	0.973	0.949	0.901	0.885	0.868
		-5	—	0.995	0.971	0.947	0.899	0.883	0.866
		-7.5	—	—	0.969	0.945	0.897	0.881	0.865
		-10	—	—	—	0.942	0.894	0.879	0.863
		-20	—	—	—	—	0.869	0.854	

6-2. Model: AOEH24KMTG

NOTE: Values mentioned in the table are calculated based on the maximum capacity.

OUTDOOR UNIT
AOEH18-24KMTG

OUTDOOR UNIT
AOEH18-24KMTG

COOLING			Pipe length (m)							
			3	5	7.5	10	15	20	25	30
Height difference H (m)	Indoor unit is higher than outdoor unit *1	25	—	—	—	—	—	—	0.893	0.877
		20	—	—	—	—	—	0.917	0.900	0.885
		10	—	—	—	0.966	0.947	0.932	0.914	0.899
		7.5	—	—	0.979	0.970	0.951	0.936	0.918	0.903
		5	—	0.992	0.983	0.974	0.955	0.939	0.922	0.906
		3	1.003	0.995	0.986	0.977	0.958	0.942	0.925	0.909
	Indoor unit is lower than outdoor unit *2	0	1.008	1.000	0.991	0.981	0.963	0.946	0.930	0.914
		-3	1.008	1.000	0.991	0.981	0.963	0.946	0.930	0.914
		-5	—	1.000	0.991	0.981	0.963	0.946	0.930	0.914
		-7.5	—	—	0.991	0.981	0.963	0.946	0.930	0.914
		-10	—	—	—	0.981	0.963	0.946	0.930	0.914
		-20	—	—	—	—	0.963	0.946	0.930	0.914
		-25	—	—	—	—	—	0.930	0.914	

HEATING			Pipe length (m)							
			3	5	7.5	10	15	20	25	30
Height difference H (m)	Indoor unit is higher than outdoor unit *1	25	—	—	—	—	—	—	0.871	0.855
		20	—	—	—	—	—	0.887	0.871	0.855
		10	—	—	—	0.952	0.903	0.887	0.871	0.855
		7.5	—	—	0.976	0.952	0.903	0.887	0.871	0.855
		5	—	1.000	0.976	0.952	0.903	0.887	0.871	0.855
		3	1.024	1.000	0.976	0.952	0.903	0.887	0.871	0.855
	Indoor unit is lower than outdoor unit *2	0	1.024	1.000	0.976	0.952	0.903	0.887	0.871	0.855
		-3	1.021	0.997	0.973	0.949	0.901	0.885	0.868	0.852
		-5	—	0.995	0.971	0.947	0.899	0.883	0.866	0.850
		-7.5	—	—	0.969	0.945	0.897	0.881	0.865	0.849
		-10	—	—	—	0.942	0.894	0.879	0.863	0.847
		-20	—	—	—	—	—	0.869	0.854	0.838
		-25	—	—	—	—	—	0.850	0.834	

7. Additional charge calculation

7-1. Model: AOEH18KMTG

Refrigerant type		R32
Factory charge amount	g	1,020

■ Refrigerant charge

Total pipe length	m	15 or less	20	25 (Max.)	20 g/m
Additional charge amount	g	0	100	200	

7-2. Model: AOEH24KMTG

Refrigerant type		R32
Factory charge amount	g	1,320

■ Refrigerant charge

Total pipe length	m	15 or less	20	25	30 (Max.)	20 g/m
Additional charge amount	g	0	100	200	300	

8. Airflow

8-1. Model: AOEH18KMTG

● Cooling

m ³ /h	2,350
l/s	653
CFM	1,383

● Heating

m ³ /h	2,100
l/s	583
CFM	1,236

8-2. Model: AOEH24KMTG

● Cooling

m ³ /h	3,240
l/s	900
CFM	1,907

● Heating

m ³ /h	2,970
l/s	825
CFM	1,748

9. Operation noise (sound pressure)

9-1. Noise level curve

Model: AOEH18KMTG

Cooling

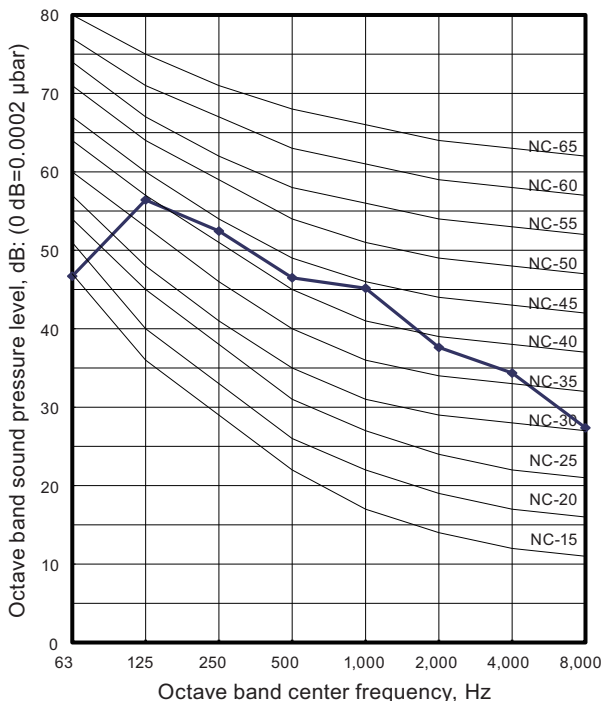

Heating

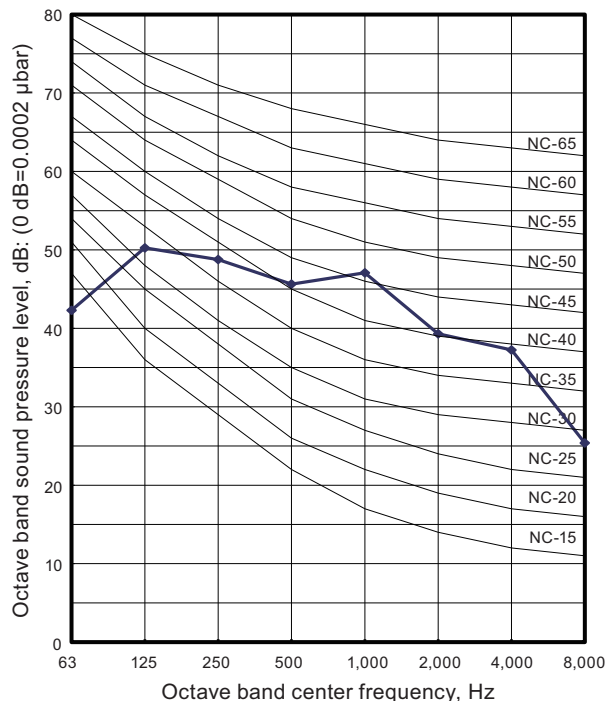

Model: AOEH24KMTG

Cooling

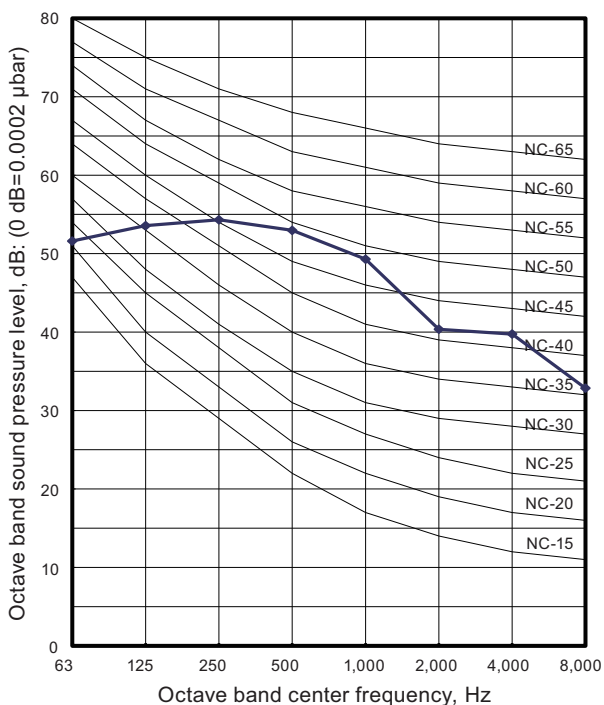

Heating

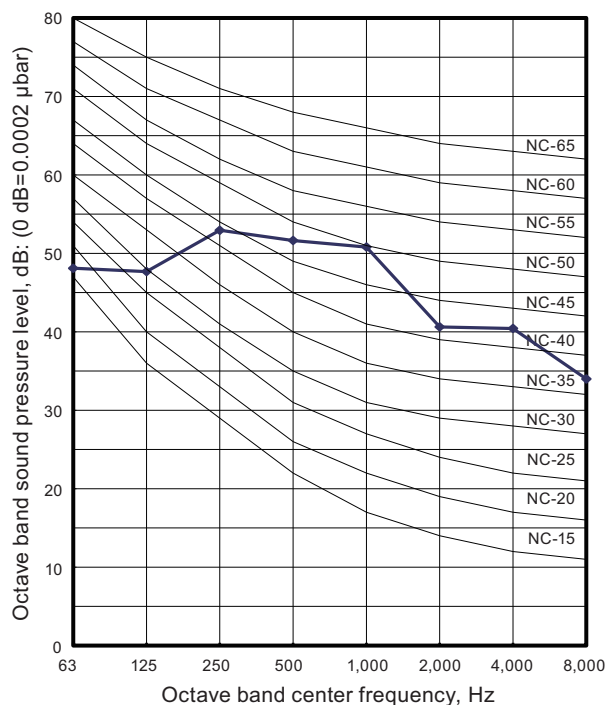

OUTDOOR UNIT
AOEH18-24KMTG

OUTDOOR UNIT
AOEH18-24KMTG

9-2. Sound level check point

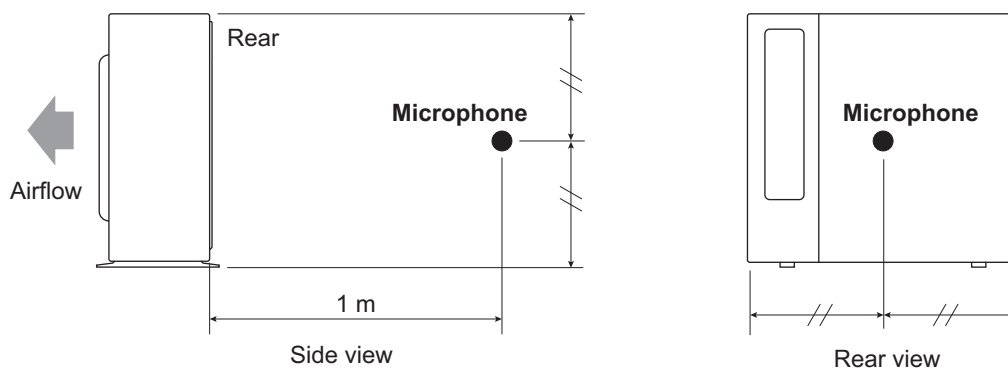

NOTE: Detailed shape of the actual outdoor unit might be slightly different from the one illustrated above.

10. Electrical characteristics

Model name			AOEH18KMTG	AOEH24KMTG	
Power supply	Voltage	V	230		
	Frequency	Hz	50		
Max operating current* ¹		A	13.5	16.0	
Starting current		A	7.0	9.8	
Wiring spec.* ²	Circuit breaker current		A	16	20
	Power cable		mm ²	1.5	2.5
	Connection cable* ³	Cross-sectional area	mm ²	1.5	
		Limited wiring length	m	26	31

NOTES:

- *¹: Maximum operating current is the total current of the indoor unit and the outdoor unit.
- *²: Selected sample based on Japan Electrotechnical Standards and Codes Committee E0005. As the regulations of wire size and circuit breaker differ in each country or region, select appropriate devices complied to the regional standard.
- *³: Limit voltage drop to less than 2%. If voltage drop is 2% or more, increase cable conductor size.



11. Safety devices

Type of protection	Protection form		Model		
			AOEH18KMTG	AOEH24KMTG	
Circuit protection	Current fuse (PCB*)		250 V, 25 A		
			250 V, 5 A		
			250 V, 3.15 A		
Fan motor protection	Thermal protection program	Activate	125 ±5°C Fan motor stop		
		Reset	115 ±5°C Fan motor restart		
Compressor protection	Thermal protection program (Compressor temp.)	Activate	—	108°C Compressor stop	
		Reset	—	After 3 minutes, and 80°C or less Compressor restart	
	Thermal protection program (Discharge temp.)	Activate	110°C Compressor stop		
		Reset	After 7 minutes Compressor restart		
	Thermal protection program (Outdoor temp.) (Only in COOL and DRY mode)	Activate	-15°C Compressor stop		
		Reset	-10°C Compressor restart		

*PCB: Printed Circuit Board

12. Accessories

12-1. Models: AOEH18KMTG and AOEH24KMTG

Part name	Exterior	Qty	Part name	Exterior	Qty
Installation manual		1	Drain pipe		1